

Our Production Process

Nails & Staples

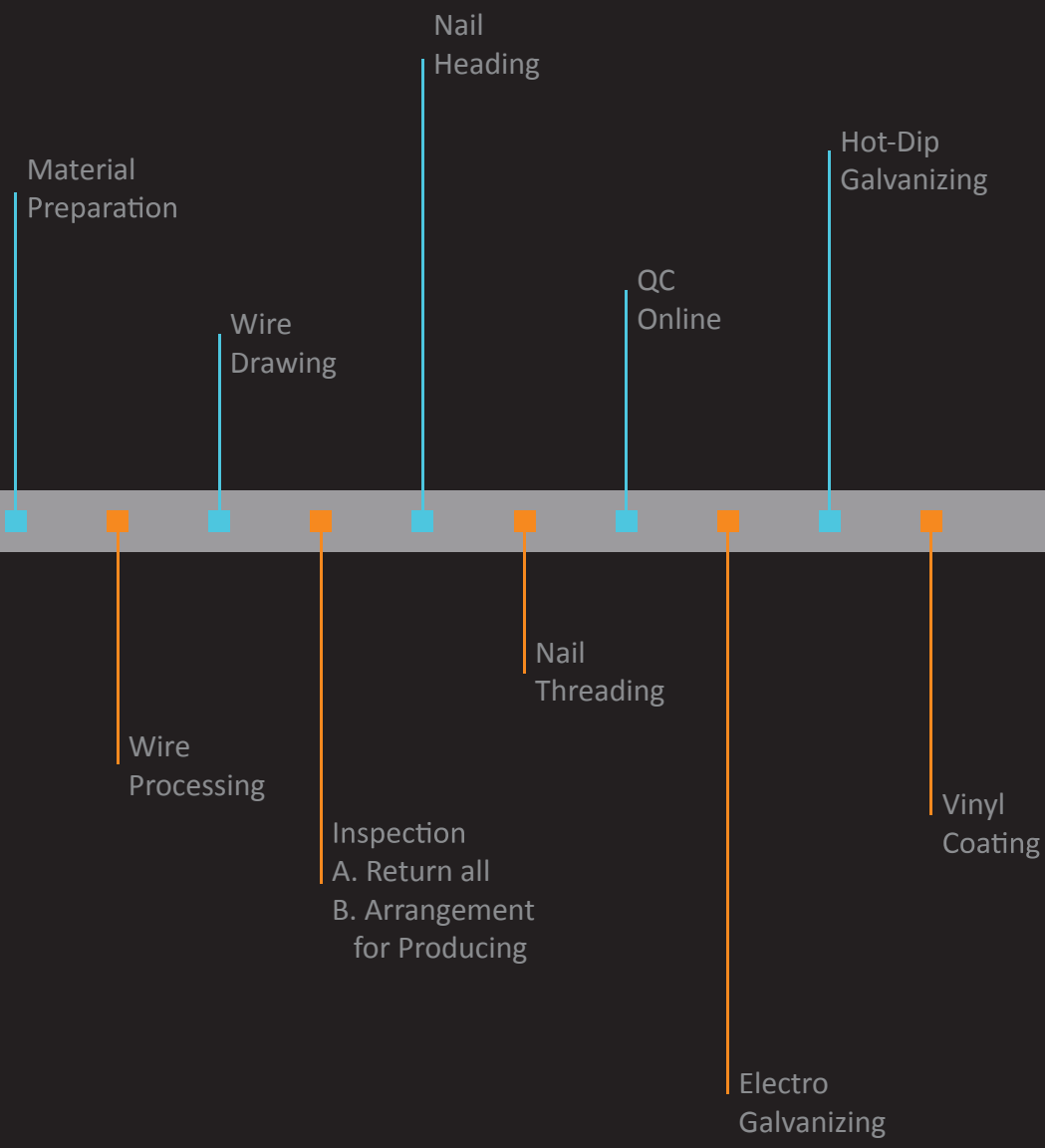

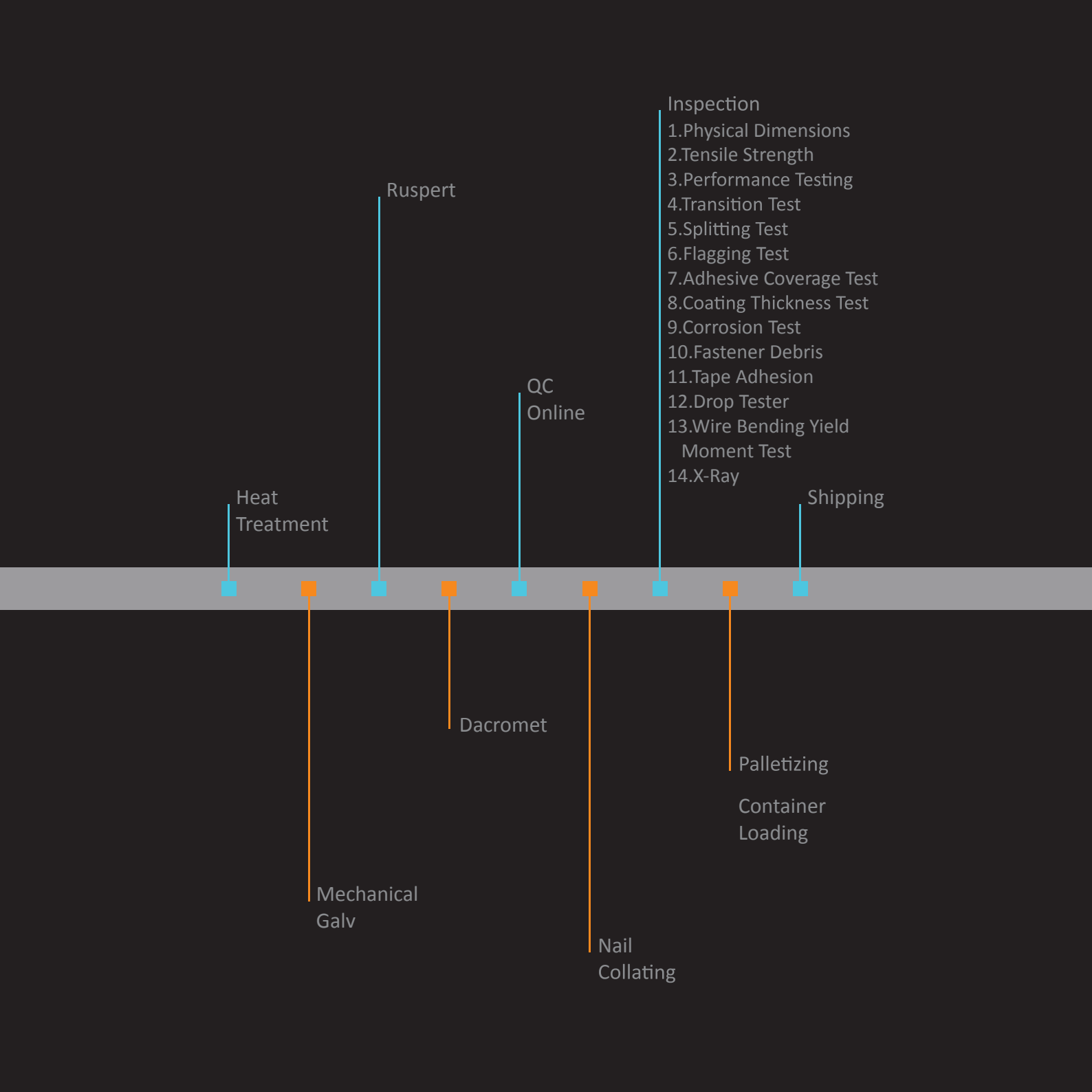

We Guarantee



Puntual delivery time



Operations & Maintenance



Careful inspection



Innovation & Quality assurance



Always care your need



Info provides



Providing a complete inspection reprot



Investment



Strongest & Sustainable package



Reduce cost



Environmental protection



Passion for result



Training



Delivering on your promise



Package design service



Ambitions



Fast Logistic



Long-term



Searching new items for you



Communication



Safety advice



VIM International Enterprise Co.,Ltd.



Instant Communication:
vimcom01@hotmail.com



Instant Communication:
vimcom01

Our Testing Facilities Cooperate With FOL Laboratory

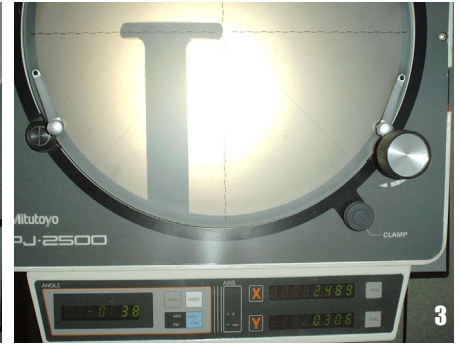
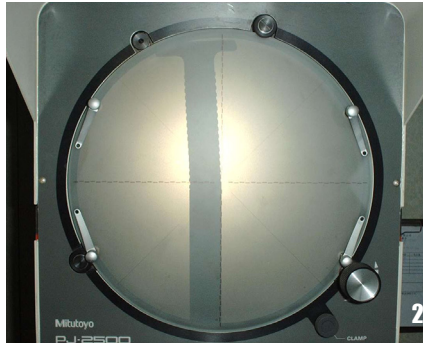

1·2·3 Overhead Projector Measurement

4 Drilling Test Machine 5 Spin Machine



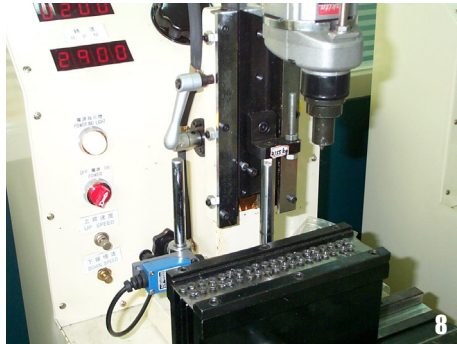

6 Vickers Hardness Tester
7 Torsional Wrench
8 Drive-in Torque Test
9 Pulverize/Burnish Machine
10
11 Head Thickness Tester



Our Testing Facilities Cooperate With FOL Laboratory





- 1·2·3 Resistance Testi
- 4 Ring Gauges
- 5 Drop Tester
- 6 Salt Spray Test
- 7·8·9 Wire Bending Yield Moment Test
- 10 Torque Wrench
- 11 X-Ray Thickness Tester
- 12 Salt Spray (Fog) Tester
- 13 Galvanization Thickness Test

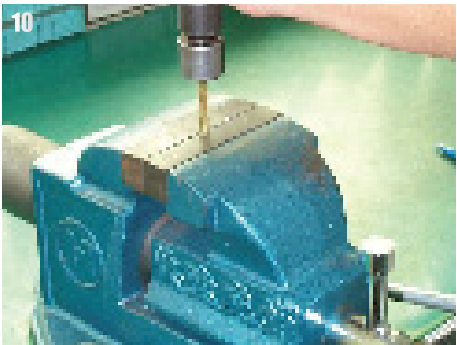

Strong And Unique Package For Nails And Staples



Plastic box for brads



Plastic box for pin nails

Strong And Unique Package For Nails And Staples



Color Box For Staples

Strip Nails

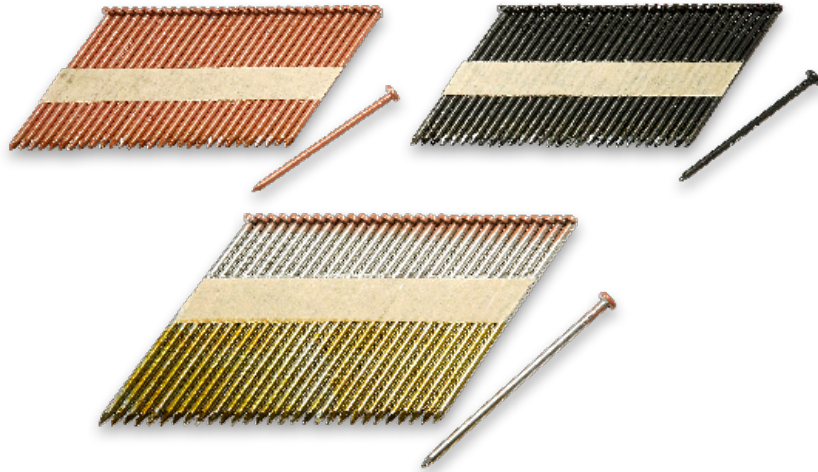

Colored Strip Nails

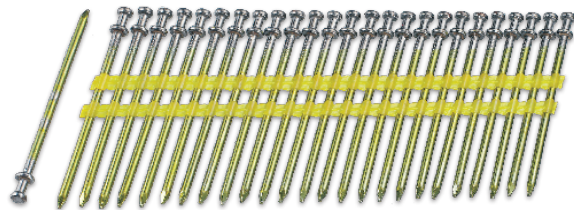

Double Head Plastic Strip Nails.

Strip Nails

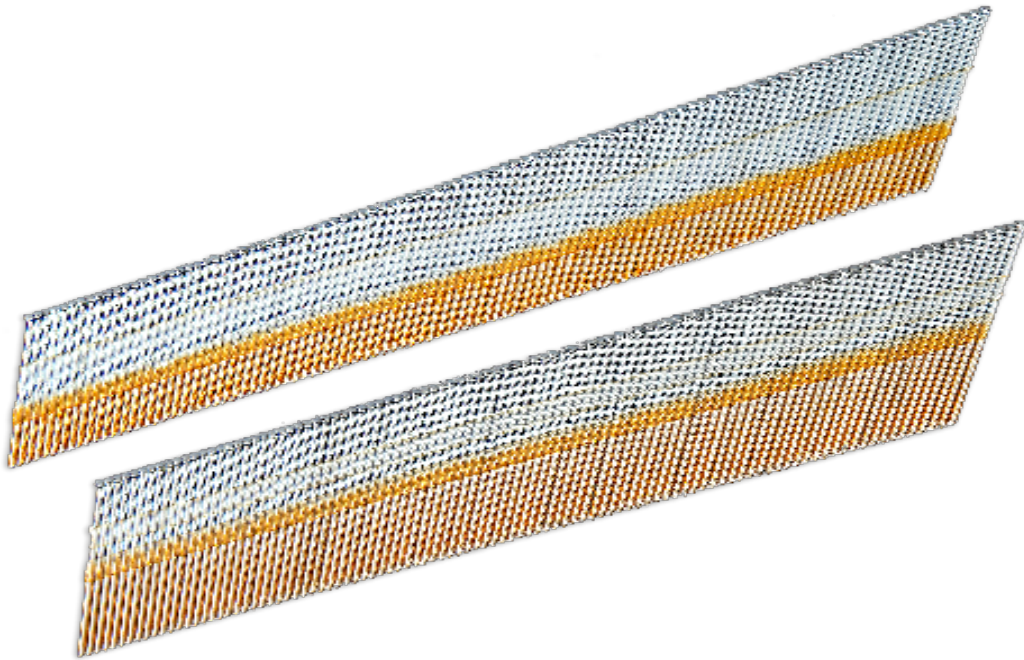

DA nails

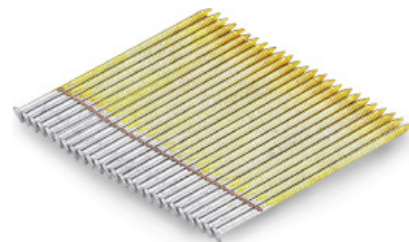

Bostitch Single Wire Strip Nails

Strip Nails



Positive placement nails

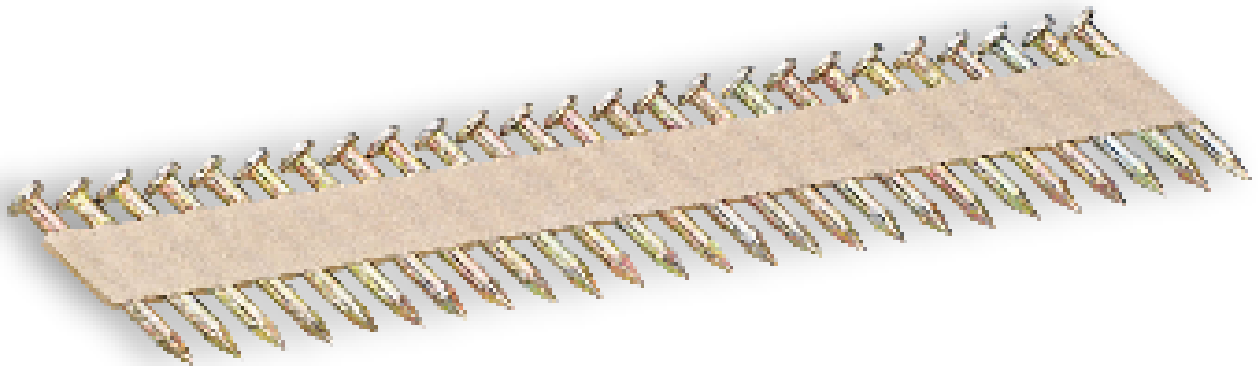

Metal Connecting Nails

Strip Nails



Anchoring Plastic Nails



Offset Head, Round Head Paper Strip Nails

Staples

Power Crown Staples

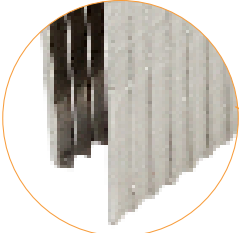
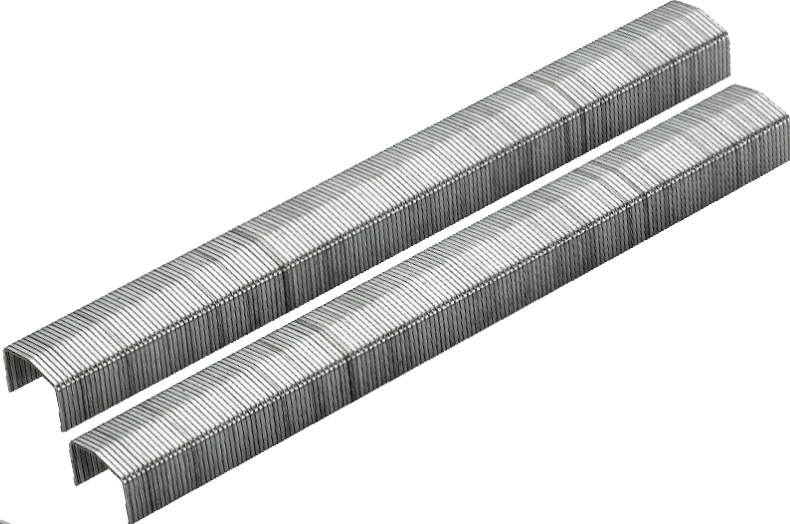
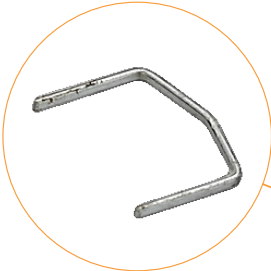

Divert Point Staples

Staples



U Staples

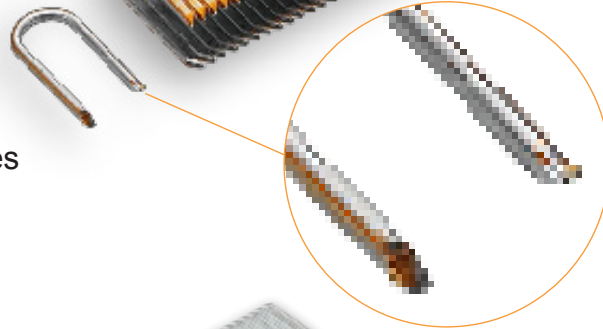

Fine Wire Staples For Hammer Tacker & Stationery

Staples

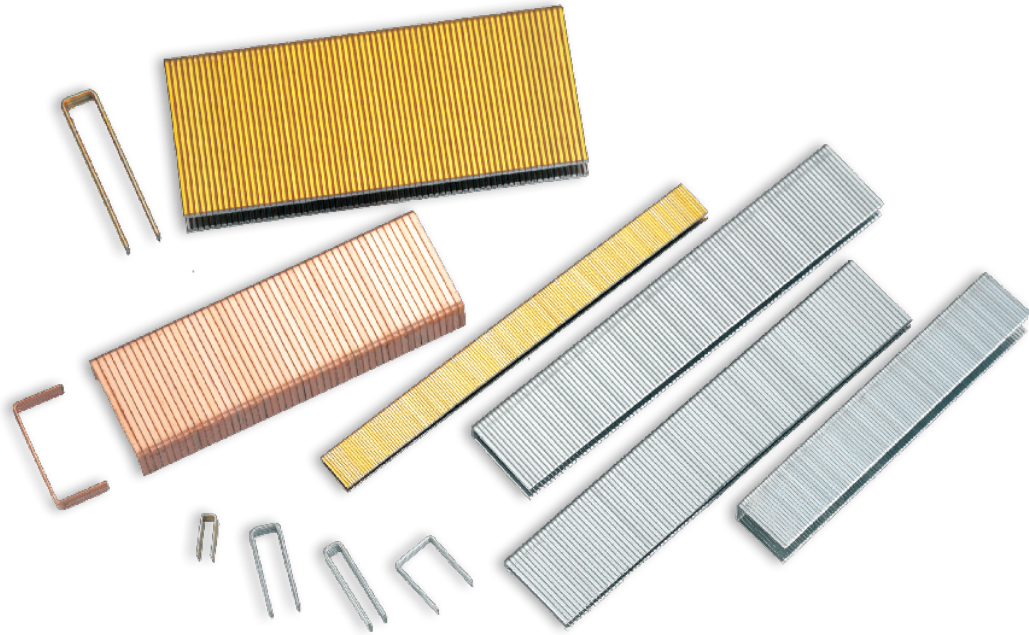

Fine Wire / Medium Wire / Heavy Duty Staples From 12-23GA.

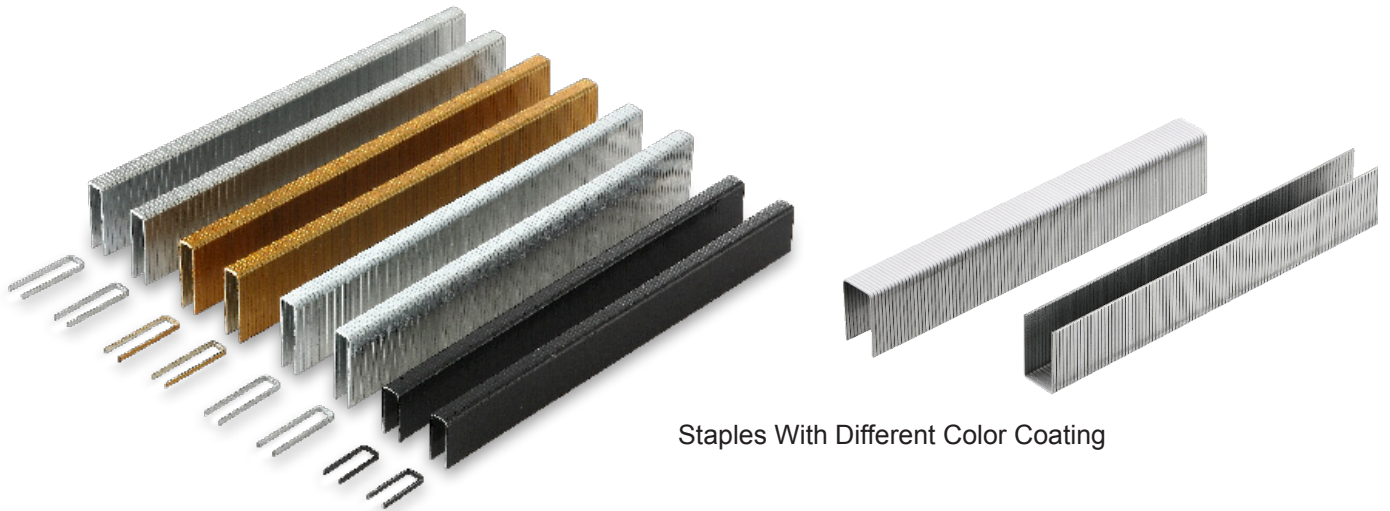

Staples With Different Color Coating

Carton Closing Stick Staples & Carton Closing Roll Staples

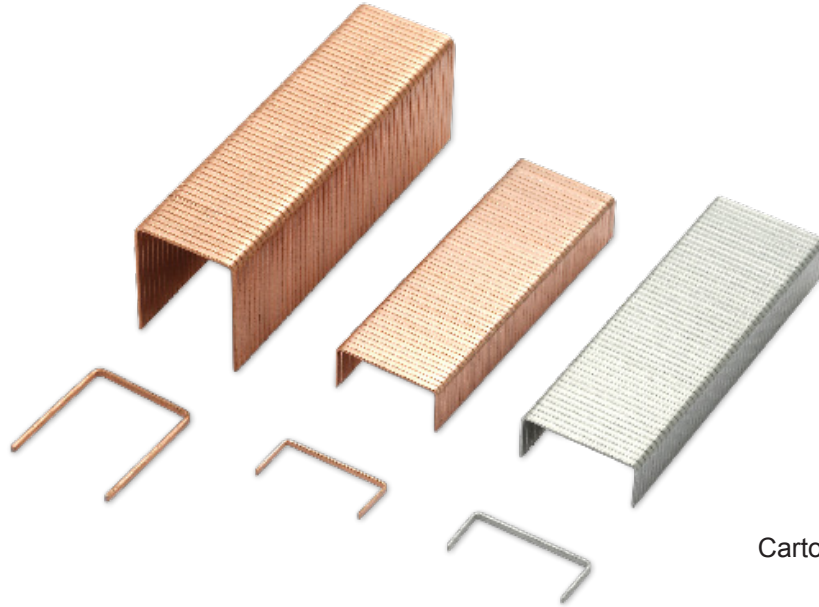

Carton Closing Stick Staples



Carton Closing Roll Staples

T Nails

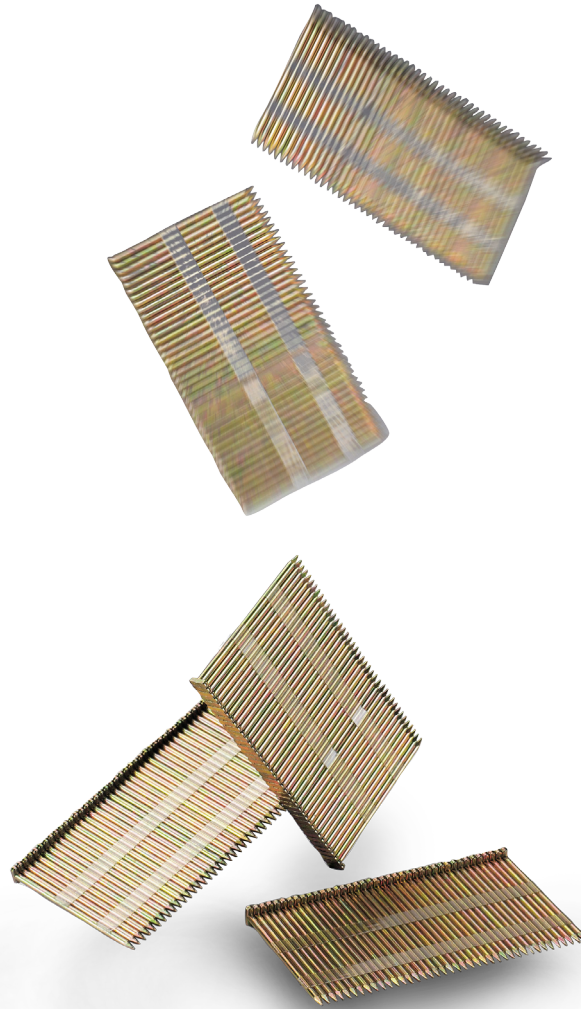

Taped Hardened T Nails will Never fall apart.

High / Low Carbon Steel T Nails

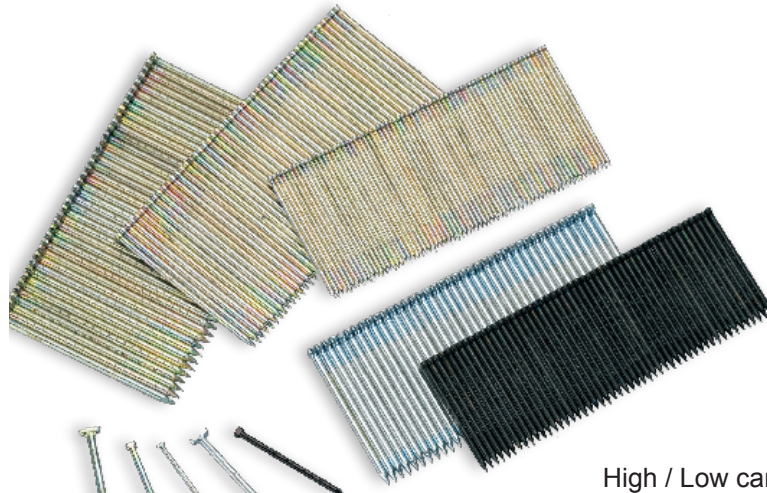

High / Low carbon steel T nails

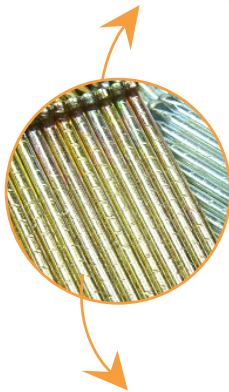

■ Nail Shank With Grip Mark



Glued Type

Pin Nails

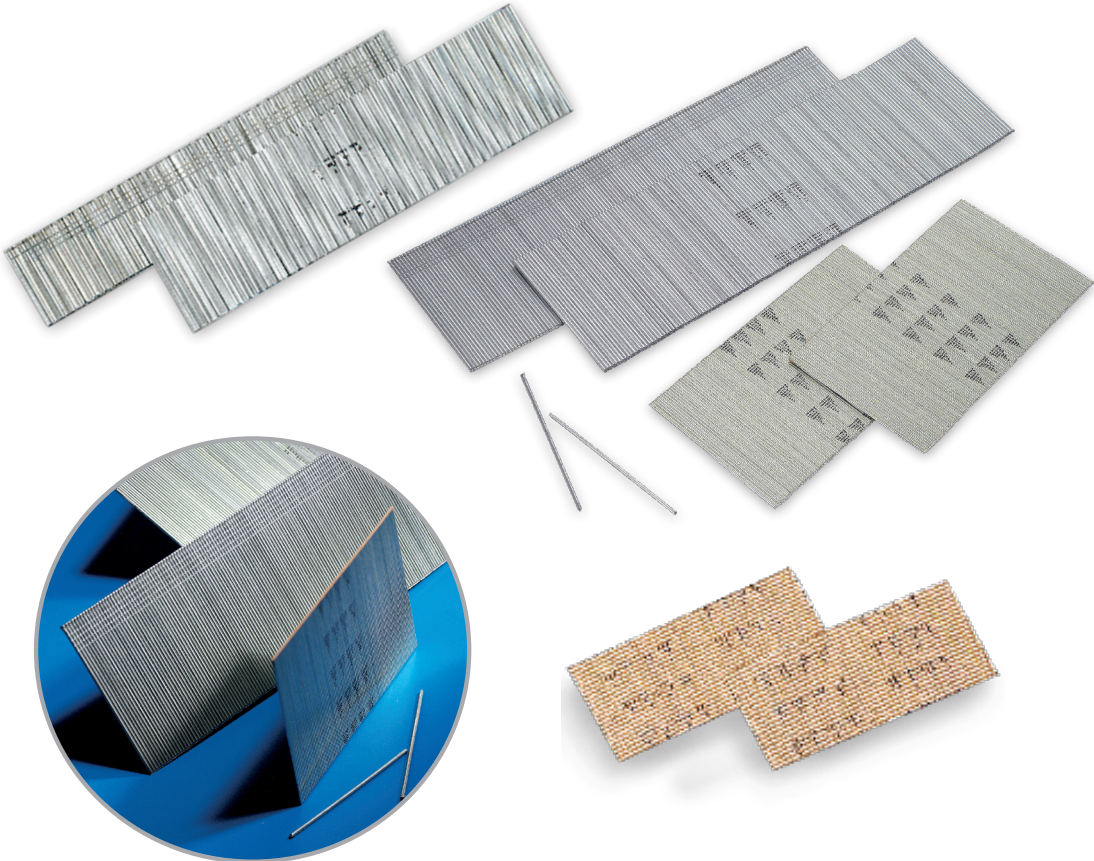

23GA. & 21GA. Headless pins and micro head pins \varnothing 0.64mm&0.84mm

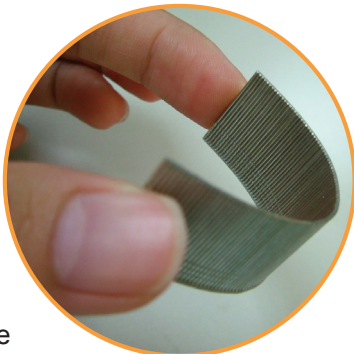

Flat and Flexible

Brads

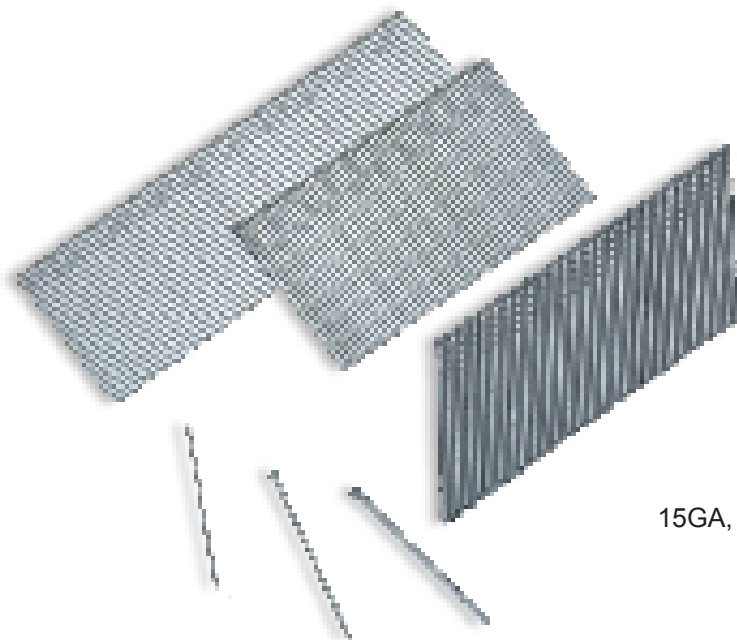

15GA, 16GA, 18GA. Angle finish nails and brads

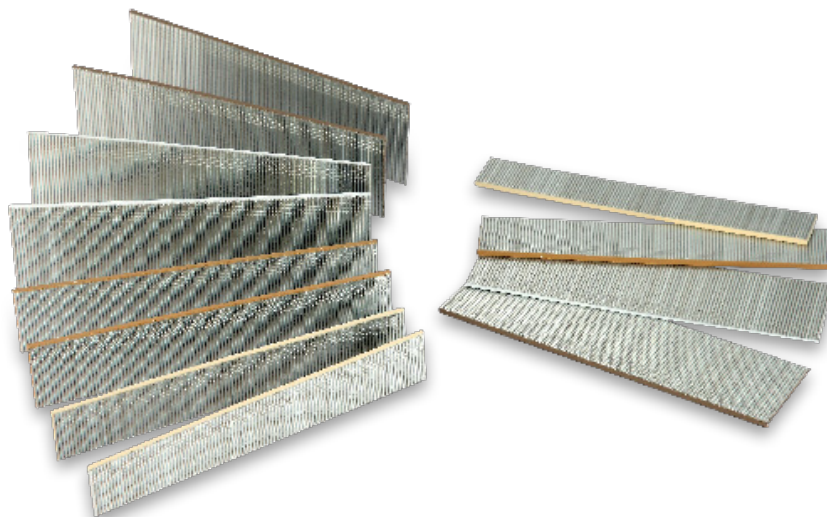

Colored Head Brads

C Rings, D Rings & Omega Rings



C-Ring, D-Ring and Omega Rings With Zinc Plated, Galvan, PVC Coated, Stainless Steel, Aluminium.

Special Nail



3000PCS/Coil

Plastic coil nails and jumbo coil nails

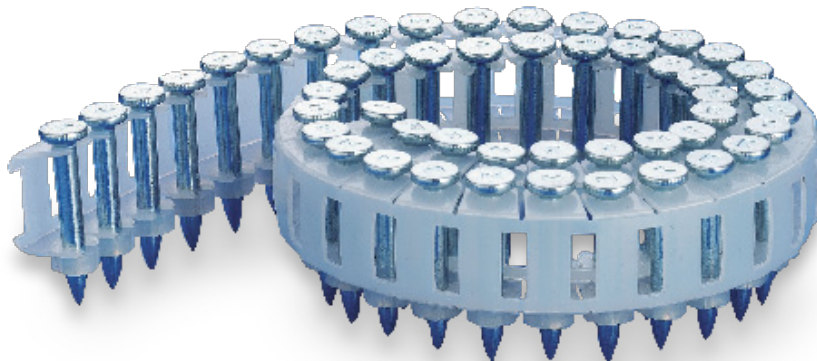

Plastic Sheet Concrete Coil Nails

ϕ 2.6~3.8mm
Length: 19~65mm

For MAX Power Lite Series HN120A ϕ 2.9~3.8mm Length: 25~64mm
MAX HN25C ϕ 2.6mm Length: 19~25mm
HITACHI NC65AC ϕ 3.7mm Length: 25~65mm

Powder Loads (Catridges)

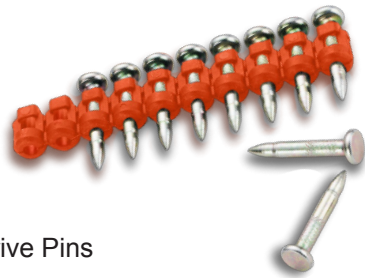

PDC Drive Pins

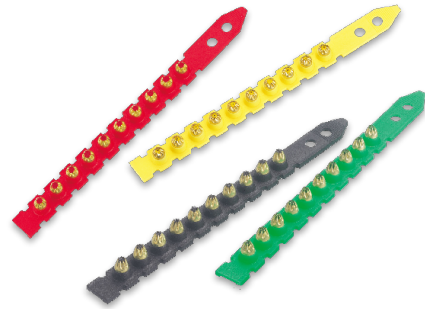

Powder loads from 6.8/11mm Black, Red, Yellow, Green



Black PDC Drive Pins (For Gas Nailer)



PDC Nails (For Gas Nailer)

- Shank Dia: 2.6mm
- Nail Length: 16mm, 19mm, 25mm, 29mm, 34mm, 38mm



AXH Nails (For Air Concrete Pinner)

Angled Concrete Drive Pins, Stepped Shank Knurling Type

- Shank Dia: 3mm
- Nail Length: 16mm, 19mm, 25mm, 29mm, 34mm, 38mm



DNC Nails (For P.A.T Tools)

- Shank Dia: 3.7mm
- Nail Length: 27mm, 29mm, 32mm, 42mm, 52mm



S3



S5



S52



S42



S43

Drive Pins

Stainless Steel Fasteners



PD-SS(Stainless Steel)



DN-SS

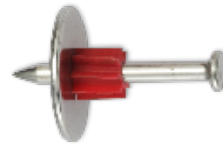

PDW-SS

Low Velocity Fasteners



EPD



PDL



CR9



PD



FM



DNTW



PDJ



NKDW

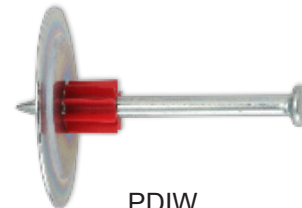

PDIW



SPD



NK



PDT



ENK



TB

Drive Pins

Low Velocity Fasteners

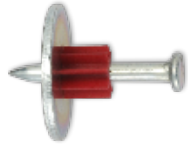

PDW



EDN



ENP

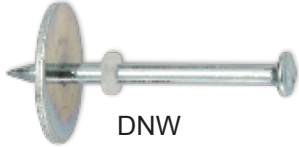

DNW



DN



DZ



DNJ



DNT



PDCB



DD



C9



PDCC



X-PC



PDCA

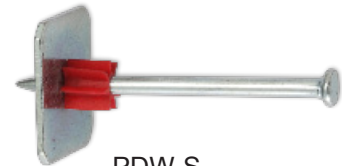

PDW-S



DNTC



X-DN



X-CC

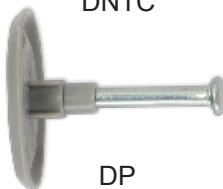

DP

Drive Pins

High Velocity Fasteners



HPD8



HPD6



HTS6/HTS1/4"



HEP6



HEP3/8



HPD 1/4



HEP 1/4

Hammer Drive Pin



HM



MK

Threaded Studs



TS 3/8"



EM6/EM8/EM10



M4/M6/M8/M10



M8



TS 1/4"

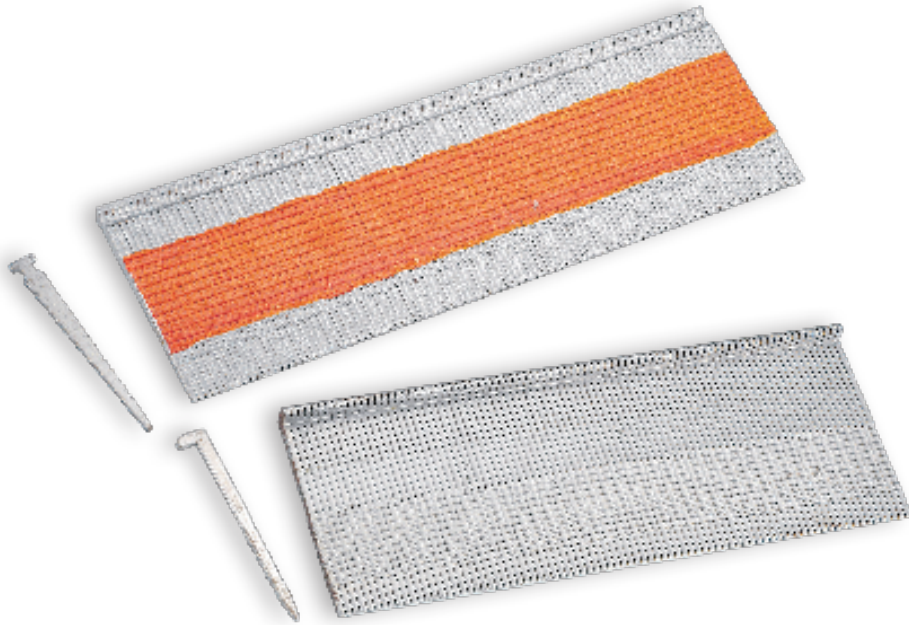

Flooring cleats and power nails



Picture Frame Wedge

Accessories for pneumatic tools

Patented 720° Rotational Quick Couplers

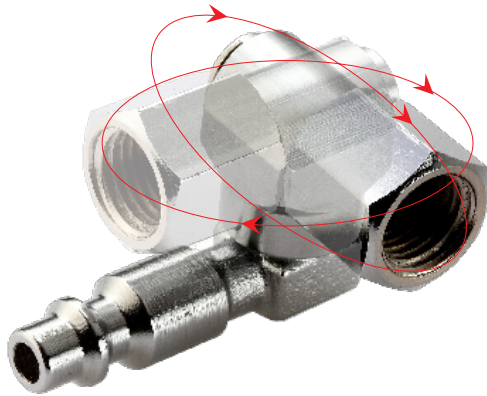

1/2"

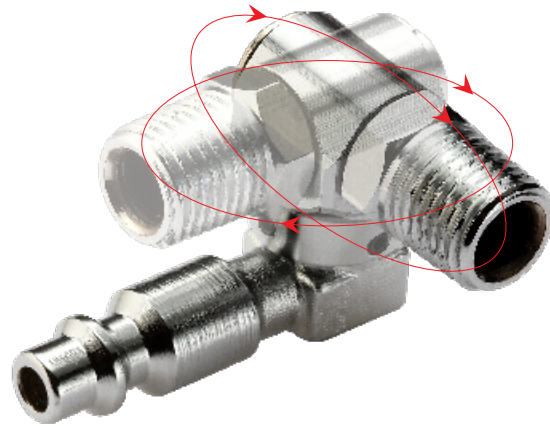

1/2"

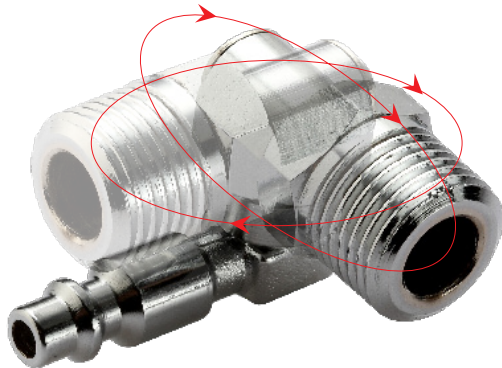

3/8"

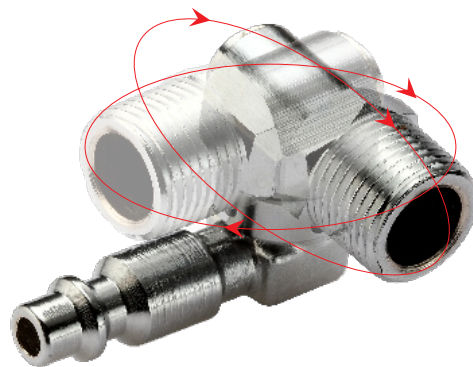

1/4"

Corrugated Nails

Comparison Chart

VIM'S CODE NO.	SUITABLE NAILER
6WB SERIES	ZB5/WB5
127NP SERIES	VIM SCF16
MCF127 SERIES	VIM MCF127
SCF16 SERIES	VIM SCF16
X SERIES	BEA BA-T358/SENCO SC2/DUO-FAST CF-100A/HAUBOLD WN15
GN20 SERIES	PASLODE MA-C20N
GCN20 SERIES	PASLODE MA-C20N

VIM'S CODE NO.	SUITABLE NAILER
WN SERIES	HAUBOLD WN25 PREBENA WN25
W SERIES	BEA BA-T358/SENCO SC2/DUO-FAST CF-100A/HAUBOLD WN15
CF SERIES	BEA BA-T358/SENCO SC2/DUO-FAST CF-100A/HAUBOLD WM15
NCF13 SERIES	BEA WM12-156

Coil Type Corrugated Nails

NR Series

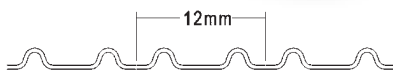
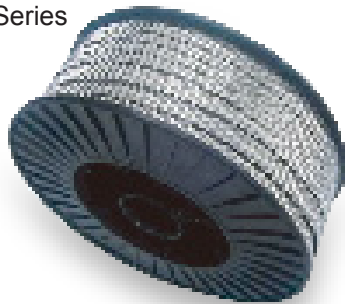

Pitch:12mm

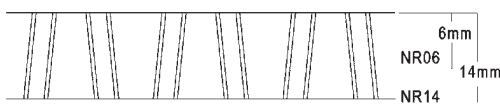

Loose Corrugated Nails

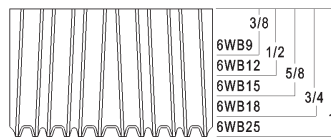
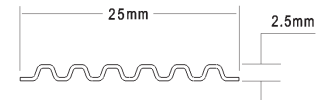
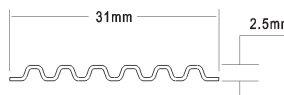
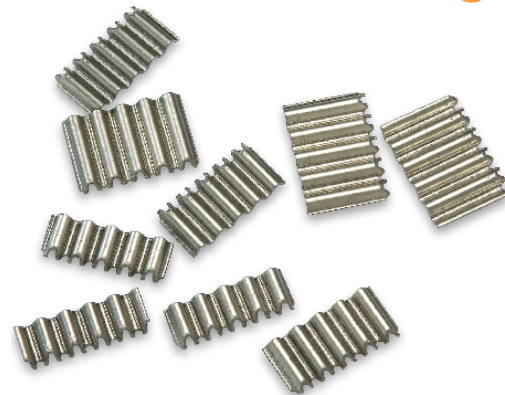

6WB Series

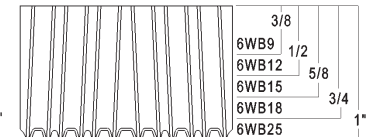

ZB5 & WB5 Series

Corrugated Nails

X Series Corrugated Nails For BeA BA-T358, Senco SC2, Duo-Fast CF-100A, Haubold WN15, Crown: 25mm

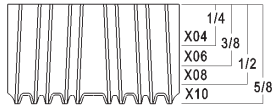
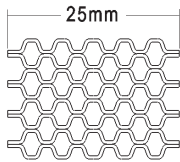
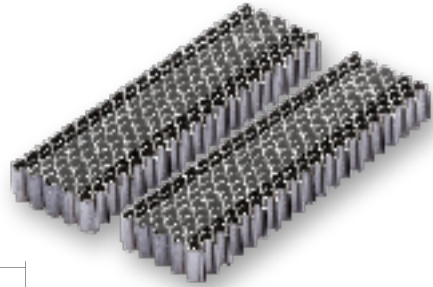

W Series Corrugated Nails For BeA BA-T358, Senco SC2, Duo-Fast, CF-100A, Haubold WN5 Crown: 24.6mm

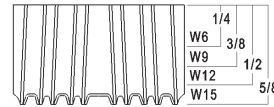
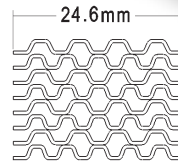
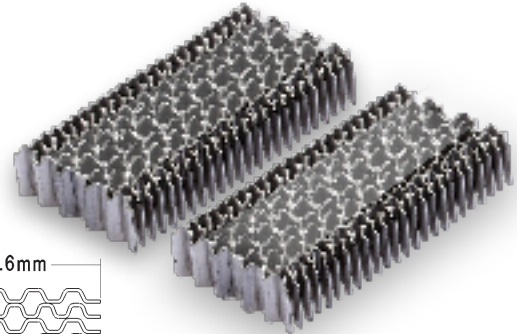

GN20 Series Corrugated Nails For Paslode MA-C20N Crown: 1"

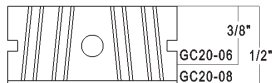
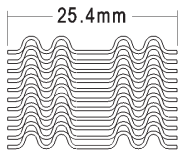
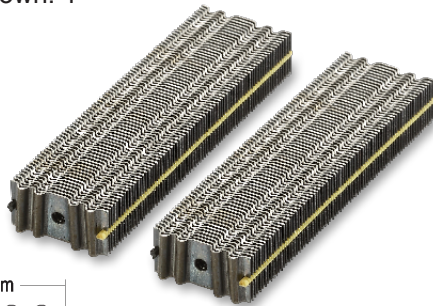

NCF13 Series Corrugated Nails For BeA WM12-156 Crown: 18.6mm

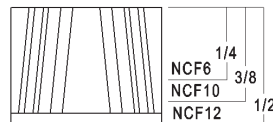
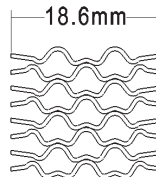
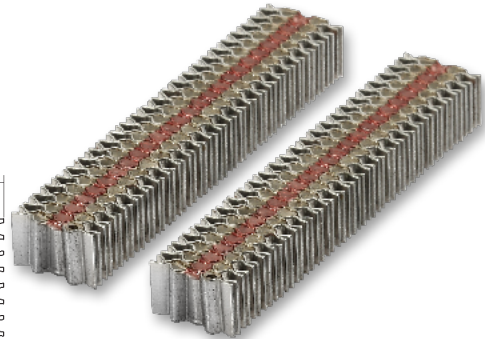

Micro Corrugated Nails

MCF127 Series MINI. Corrugated Nails.

SCF16 Series Mini Corrugated Nails.

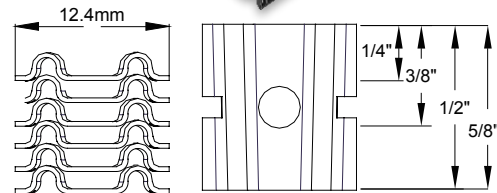
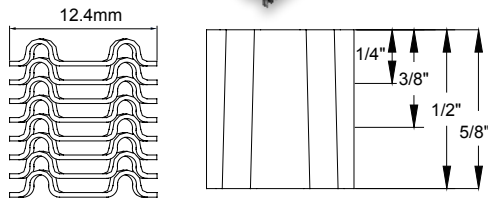

127NP Micro Corrugated Fasteners. Crown:
12mm For SCF16 Nailer

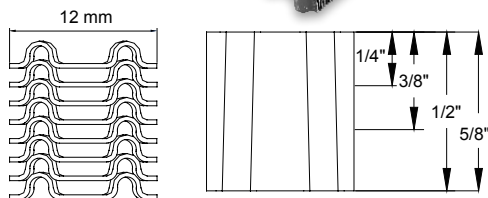
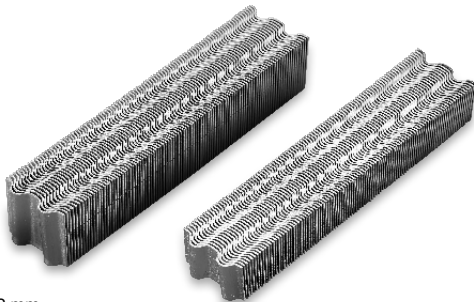

V Nails

SOFT TYPE 5.15mm
HARD 7.10.12mm

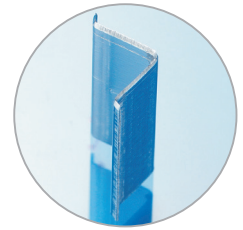

V Nails

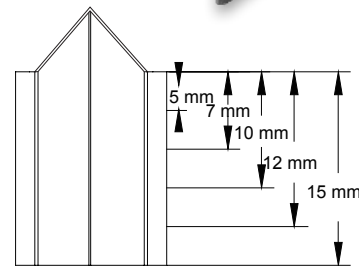
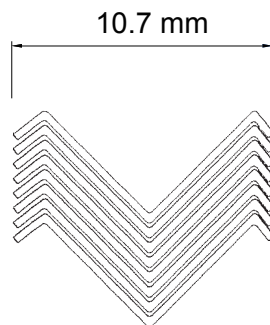
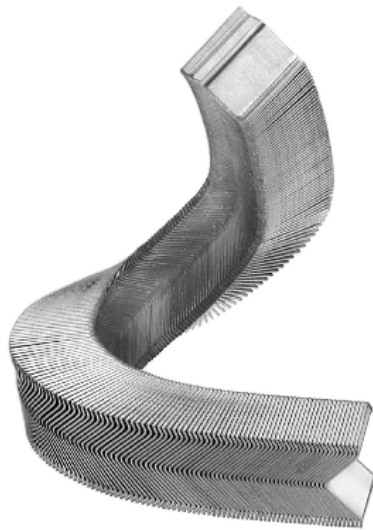

Corrugated Nails

WN Series/JCF Series Jumbo Corrugated Nails For

1. Haubild WN18 x 1, WN25 x 11
2. Prebena WN25SNS
3. BeA W25

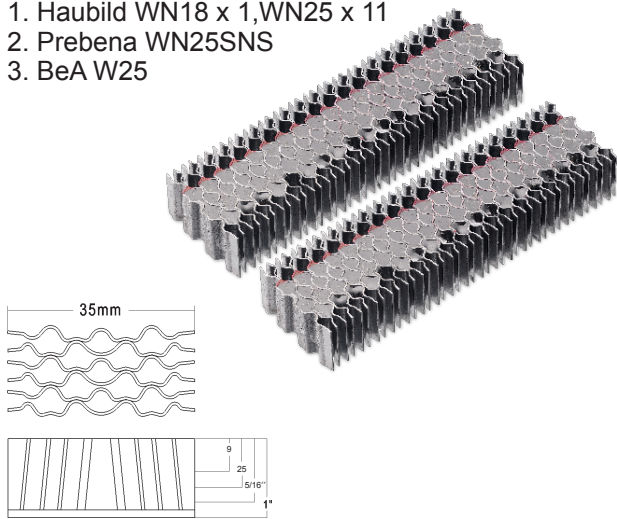

GCN20 Series Corrugated Nails For Paslode
MA-C20N Crown: 1/2"

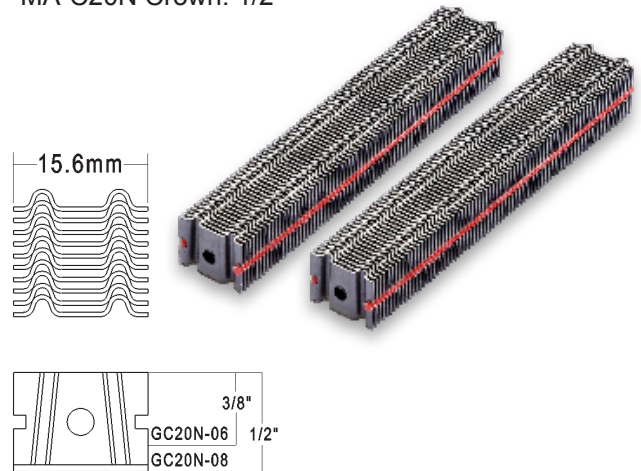

CF Series Corrugated Nails For BeA BA-T358 SENCO SC2 Duo-Fast CF-100A,
Haubold WM15 Crown: 24.6mm

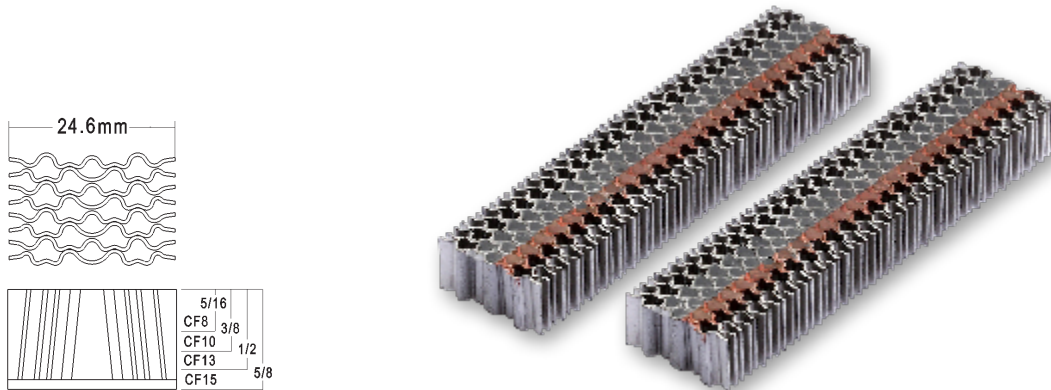

WM Series Corrugated Nails for BeA WM12-156

Crown: 18.6mm
Length: 1/4" , 3/8" , 1/2"

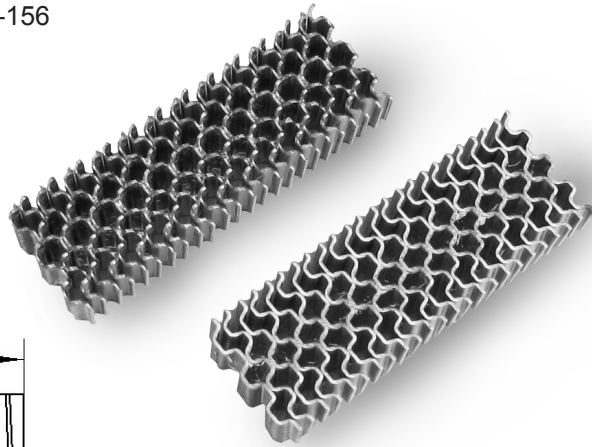
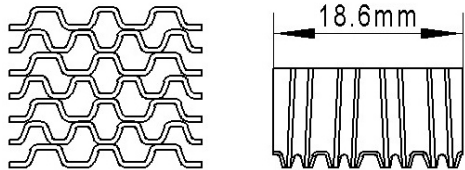

M Mattress Nails
CL-73, CL74

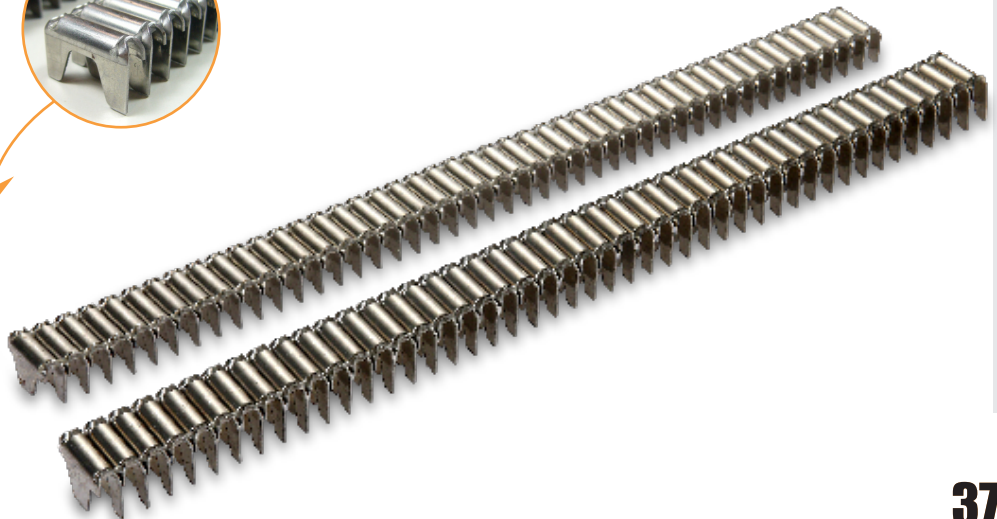
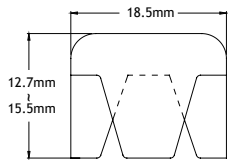



AFTER MARKET DRIVER ASSEMBLY

HITACHI, MAX, PASLODE, BOSTICHI,...etc.

AFTER MARKET DRIVER ASSEMBLY

BOSTITCH MODEL NO.	BOSTITCH PART NO.
N57C	104345
N70	102630

PASLODE MODEL NO.	PASLODE PART NO.
IM350	P404485
3225 / CN55	405351
4275 / CN70	405343
5325 / CN80	CN34445

MAX MODEL NO.	MAX PART NO.
CN450R	CN35476
CN550S	CN35782
CN552S	CN34996
CN565D	CN70028
CN55	CN31866
SN883RH	CN70091
CN70	CN31657
CN80	CN34445
CN565S	CN35782
CN452S	CN35181
CN238	CN70114

HITACHI MODEL NO.	HITACHI PART NO.
NR83AA2 / NR83AA3	883-510
NR90AE	885-519
NR65AK	883-471
NR90AD	884-957
NR83A2	877-323
NV83A	878-428
NR83	877-323R
NV45AB2	878-156
NV65AH	882-684
N5008AC	883-716
NV75AG	883-980
N90AB2	N/A

Patented 720° Rotational Quick Couplers

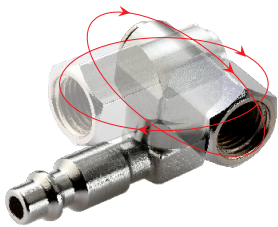

1/2"

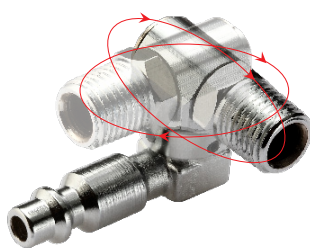

1/2"

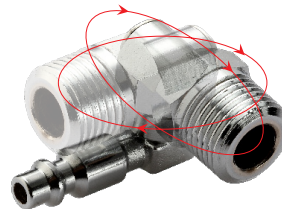

3/8"

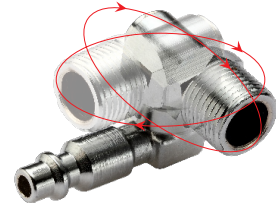

1/4"

Piston Units

Nailer No. MAX-CN55,
Paslode 3225,CN55, Bostitch CN57
No. MAX-CN31866, Paslode-405300



Nailer No. MAX CN70, Bostitch N70,
Paslode 4275, CN70, Apach CN70E
No. MAX-CN31657, Bostitch 102630,
Paslode 405301



Nailer No. MAX CN80, Paslode 5325,
CN80, Fasco F58C CN15W-80
No. MAX CN34445, Paslode 405397,
Fasco300806 CPL



Nailer No. MAX CN238
NO. MAX 70114



Piston Units

Nailer No. MAX 450R
No. MAX CN35476



Nailer No. MAX CN452S
No. MAX CN35181



Nailer No. MAX CN550S
No. MAX CN35782



Nailer No. MAX CN552S
No. MAX CN34996



Piston Units

Nailer No. MAX CN565D
No. CN70028



Nailer No. MAX CN565S
No. MAX CN35782



Nailer No. MAX SN883RH
No. MAX CN70091



Nailer No. MAX CN55, CN70, CN80
No. MAX SA0001A



Piston Units

Nailer No. Hitachi N90AB2
No. N/A



Nailer No. Hitachi N5008AC
No. Hitachi 883-716



Nailer No. Hitachi NR65AK
No. Hitachi 883-471



Nailer No. Hitachi NR83
No. Hitachi 877-323R



Piston Units

Nailer No. Hitachi NR83A2
No. Hitachi 877-323



Nailer No. Hitachi NR83AA2,
NR83AA3
No. Hitachi 883-510



Nailer No. Hitachi NR90AD
No. Hitachi 884-957



Nailer No. Hitachi NR90AE
No. Hitachi 885-519



Piston Units

Nailer No. Hitachi NV45AB2
No. Hitachi 878-156



Nailer No. Hitachi NV65AH
No. Hitachi 882-684



Nailer No. Hitachi NV75AG
No. Hitachi 883-980



Nailer No. Hitachi NV83A
No. Hitachi 878-428



C3040A

12GA. 21° Plastic Collated Concrete Nailer

L x W x H	370x130x330 mm
Weight	2.6 kgs
Gauge	12 GA
Shank Dia	3.00 mm (0.118")
Fastener Range	15~40mm (5/8"-2")
Loading Capacity	35 pcs
Working Pressure	6~9 bar/80~125 psi

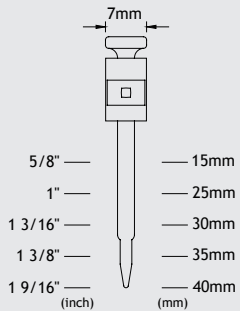

- Heat-Treated Plastic Collated Concrete Nails For C3040A

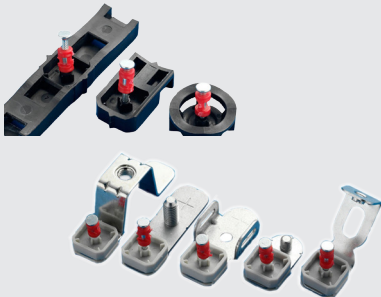

46

FASTENING A DIFFERENCE



APPLICATION

- Reinforce construction
- Tectonic floor
- Drywall and partition
- Steel to concrete
- Steel to steel

FEATURES

- Angled magazine for accurate fastener placement
- Powerful
- Nail length depth adjustment dial
- Easy bottom loading
- No-Mar Tip to protect work surface
- Rubber grip for comfort



Reinforce Construction



Reinforce Construction

C3040 12GA. 0° Straight Collated Concrete Nailer



L x W x H	380x130x330 mm
Weight	2.6 kgs
Gauge	12 GA
Shank Dia	3.00 mm (0.118")
Fastener Range	15~40mm (5/8"~2")
Loading Capacity	35 pcs
Working Pressure	6~9 bar/80~125 psi

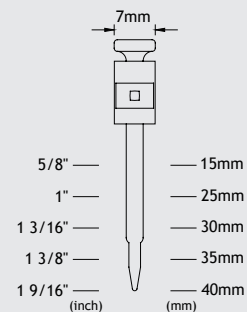

- Heat-Treated Plastic Collated Concrete Nails For C3040

APPLICATION

- Reinforce construction
- Tectonic floor
- Drywall and partition
- Steel to concrete
- Steel to steel

FEATURES

- Angled magazine for accurate fastener placement
- Powerful
- Nail length depth adjustment dial
- Easy bottom loading
- No-Mar Tip to protect work surface
- Rubber grip for comfort

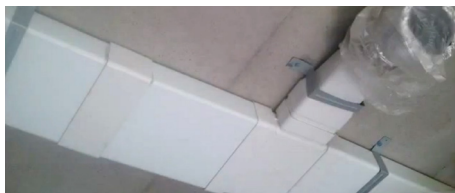

Reinforce Construction



Reinforce Construction

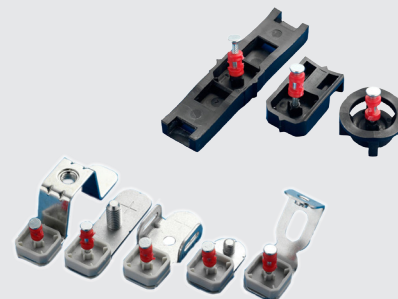

47

HR1845/HR1850/HR1855/HR1865/HR1880 15GA. HOG RING PLIER

1 SECOND 3 SHOTS



Stanley Spenax SC4CLW, SC7C

APPLICATION

- Pocket spring mattress assembly
- Car seating assembly
- Mattress upholstery (Bedding Industry)
- BAG closure
- Fences, greenhouses, cages assembly
- Industry in general

FEATURES

- Long fiber compounds make it lighter and faster
- Reduce operator fatigue
- Easy loading process
- Muffler inside provides silent operation
- Extended magazine for loading 130 pcs of hog ring is available



Mattress, spring industry

L x W x H	325x90x205 mm
Weight	1.54 kgs
Staple Crown	23.7 mm
Shank Dia	1.8 mm
Closure Size	4.5, 5.0, 5.5, 6.5, 8.0 mm
Loading Capacity	130 pcs
Working Pressure	5~7 bar/90~105 psi

Round Type

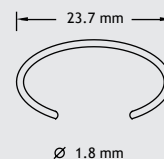

Closure Size

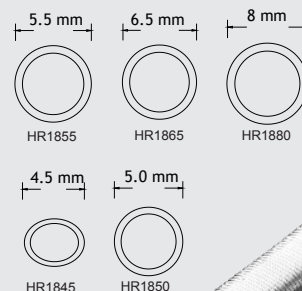

49

FASTENING A DIFFERENCE

HR1880L 15GA. HOG RING PLIER WITH EXTENSION NOSE

L x W x H	355x90x205 mm
Weight	1.56 kgs
Staple Crown	23.7 mm
Shank Dia	1.8 mm
Closure Size	8.0 mm
Loading Capacity	130 pcs
Working Pressure	5~7 bar/90~105 psi

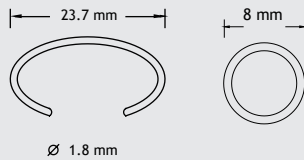

1 SECOND 3 SHOTS



APPLICATION

- Pocket spring mattress assembly
- Car seating assembly
- Mattress upholstery (Bedding Industry)
- BAG closure
- Fences, greenhouses, cages assembly
- Industry in general

FEATURES

- Long fiber compounds make it lighter and faster
- Reduce operator fatigue
- Easy loading process
- Muffler inside provides silent operation
- 60.5 mm extended nose for coiling deeper corner
- Extended magazine for loading 130 pcs of hog ring is available



Car Seat Industry



Sofa Industry

50

HR1630,/HR1648 16GA. HOG RING PLIER

1 SECOND 3 SHOTS



L x W x H	285x100x200 mm
Weight	1.56 kgs
Staple Crown	16.9 mm
Shank Dia	1.6 mm
Closure Size	3.0/4.8mm
Loading Capacity	100 pcs
Working Pressure	5~7 bar/90~105 psi

Oval Type

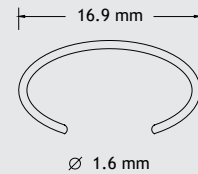

Closure Size



APPLICATION

- Pocket spring mattress assembly
- Car seating assembly
- Mattress upholstery (Bedding Industry)
- BAG closure
- Fences, greenhouses, cages assembly
- Industry in general

FEATURES

- Long fiber compounds make it lighter and faster
- Reduce operator fatigue
- Easy loading process
- Muffler inside provides silent operation
- Extended magazine for loading 130 pcs of hog ring is available



SCF16/MCF127 Mini Corrugated Nailer

SCF16

L x W x H	355x90x205 mm
Weight	1.56 kgs
Staple Crown	12 mm
Shank Dia	2.2 mm
Fastener Range	6~16 mm
Loading Capacity	200 pcs
Working Pressure	6~8 bar/85.2~114 psi

SCF127

L x W x H	355x90x205 mm
Weight	1.56 kgs
Staple Crown	12.4 mm
Shank Dia	2.2 mm
Fastener Range	6~16 mm
Loading Capacity	200 pcs
Working Pressure	6~8 bar/85.2~114 psi

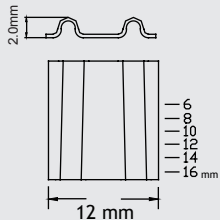

SCF16 NAILS SPEC.

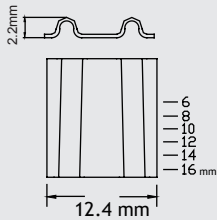

MCF127 NAILS SPEC.

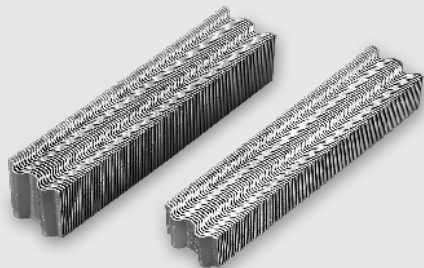

APPLICATION

- Trackless Carpet Strip
- Wood Furring
- Floor underlay
- Carpet edge molding
- Installation of metal drywall track
- Door & Window
- Furniture and Cabinet making
- Face Frames
- Picture & Mirror frames
- All kinds of mitre joint especially where MDF is used
- Compact, light weight, powerful
- Extra big loading capacity for professional users

FEATURES

- Plastic end core provide comfort usage
- PATENTED Tool-Free nail length adjustment
- Adjustable deflector conveniently directs exhaust
- Quick bottom loading
- View Window for re-loading nails easily

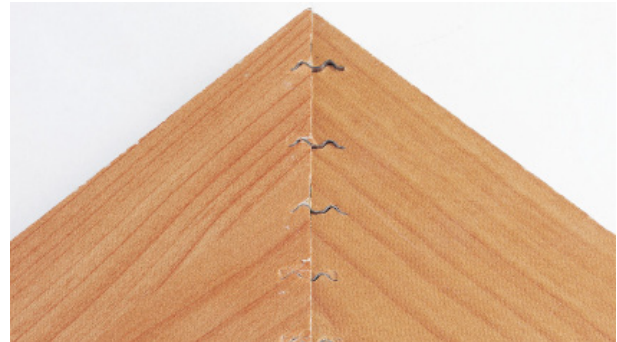

Butt Joints. Inside Mitres. Outside Mitres, Picture Frames and Face Frames



PATENTED Tool-free nail length adjustment



View Window for re-loading nails easily

CN55M 16° WIRE COLLATED COIL NAILER

L x W x H	270x131x283 mm
Weight	2.5 kgs
Angle	16°
Shank Dia	2.1 mm/0.083" 2.3 mm/0.092"
Fastener Range	25-57 mm 1"-2-1/4"
Shank Type	Smooth Ring Screw
Loading Capacity	300-400 PCS
Working Pressure	5-7kg/ cm2 (70-100psi)

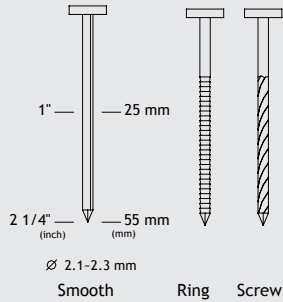

APPLICATION

- Sheathing
- Decking
- Subflooring
- Pallets
- Crate & Box Assembly

FEATURES

- Construction work, such as siding, roofing and sheathing.
- Production of wooden boxes light pallets, wooden furniture, wooden sashes and other wood products
- Packing operations in manufacturing plants and other types of general packing and cratgn work
- All spare parts compatible with MAX CN55

CN57U

16° WIRE COLLATEO COIL NAILER

L x W x H	270x130x290 mm
Weight	2.8 kgs/6.16 lbs
Angle	16°
Shank Dia	2.3 mm/0.092" 2.5 mm/0.99"
Fastener Range	25-57 mm 1"~2-1/4"
Shank Type	Smooth Ring Screw
Loading Capacity	300-350 PCS
Working Pressure	5-70kg/ cm2 (70-100psi)

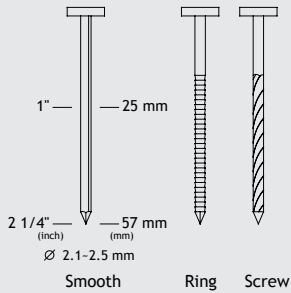

APPLICATION

- Sheathing
- Decking
- Subflooring
- Pallets
- Crate & Box Assembly

FEATURES

- Exhaust Bumper with upgraded material outlasts extreme temperatures between -4°F (-20°C) to 176°F (80°C)
- Cylinder Seal lasts up to 5 years
- Driver Assembly increases the durability
- Bumper with upgraded material extend its durability up to 5 years

56

FNU21160

21° Plastic Collated Framing Nailer

L x W x H	555x135x540 mm
Weight	7.4 kgs
Angle	21°
Shank Dia	3.8~5.0 mm
Fastener Range	100~160 mm 4"~6-5/16"
Shank Type	Screw
Loading Capacity	by 130 mm-50 pcs by 160 mm-60 pcs
Working Pressure	7~9kg/cm ² (120psi)

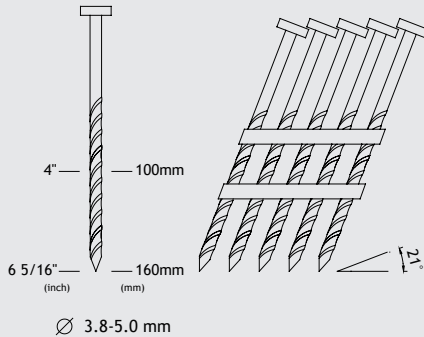

APPLICATION

- Architectural woodworking
- Sash & mill working
- Pallet manufacturing
- Joint assembly
- Trusses, sheathing, Decking
- Framing Udemusatum ine dem et

FEATURES

- Well-Balanced body reduces fatigue
- Auto Lock-out prevents dry-firing of the tool
- Single firing provide highest safety and reliability
- Very Powerful, suitable for hard wood
- Ideal for hard wood working
- Drive a wide variety of ture framing nailer application
- With anti-dry firing device

58

PN4840 Positive Placement Metal Connector Nailer



L x W x H	292x90x279 mm
Weight	2.2 kgs
Fastener Range	38 mm
Shank Dia	4.15mm
Load Capacity	29 pcs
Working Pressure	5.5~8.5 bar (80~12psi)

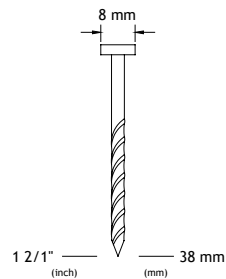

APPLICATION

- Strapping
- Joist hangers
- Hurricane ties
- Anchors
- Rafter ties / Connectors

FEATURES

- Fast and productive to install metal straps
- Lower installed cost
- Durable, low maintenance
- Soft grip handle for comfort
- Probing tip targets metal strap hole easily



BM1850C 18GA. Mini. Concrete Nailer

L x W x H	260x67x243 mm
Weight	1.11 kgs
Gauge	18 GA
Shank Dia	1.20 mm(0.50")
Fastener Range	15~50mm (5/8"-2")
Loading Capacity	100 pcs
Working Pressure	5~7 kg/cm2/70~100 psi

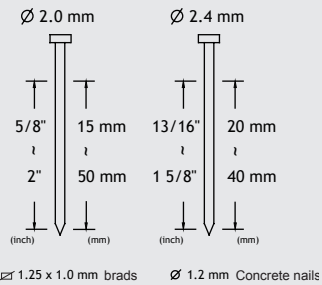

Applications:



APPLICATION

- Furniture upholstery, light furniture/cabinet assembly
- Light-framing, packaging, trim and molding
- Wood to concrete

FEATURES

- Multi-directional exhaust deflector
- Cushioned rubbergrip provides greater comfort and less fatigue
- Storage compartment for the no-mar tip
- Open drive channel for easy jam clear
- Side loading magazine
- Optional: Standard trigger Sequential fire trigger
- Depth adjustment for precision nailing
- No-mar tip for soft wood
- Slender nose for tighten space
- Visual reload indicator
- All new ergonomically designed gunbody, maximizes comfort and ease of handing

60

FASTENING A DIFFERENCE

RPT840F 21GA. 2 IN 1 Pin Nailer With Front Exhaust



APPLICATION

- Light wood assy
- Finish and trim work
- Decorative trim
- Dowel and joint pinning
- Mirror and picture frame assy
- Glazing strips
- Craft work
- Paneling external softwood trim
- Wall framing
- Truss construction
- Roofing
- Rettan furniture
- Window beading
- Display and sign work

FEATURES

- Drives headless pins and micro head brads
- Front exhaust
- The patented adjust-free magazine for easy using any fastener length
- Double trigger safety lock helps prevent accidental firing of the tool
- Removable Nose Cover provides easy access to clear fastener jams
- A narrow nose on the pinners allows the tool to reach into tight areas, and detailed work surfaces
- The window on the magazine can show if fasteners are low and when reloading is necessary
- Rubber grip for comfort usage

L x W x H	250x43x200 mm
Weight	1.2 kgs
Gauge	21 GA
Shank Dia	0.84 mm(0.033")
Fastener Range	12~40 mm (1-5/32"~1-9/16")
Shank Type	Smooth
Loading Capacity	100 pcs
Working Pressure	5~7 bar/70~100 psi

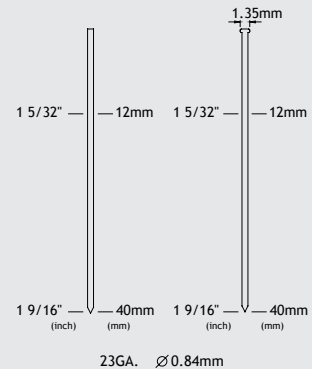

RPT850R

21GA. 2 IN 1 Pin Nailer With Rear Exhaust

L x W x H	255x60x225 mm
Weight	1.35 kgs
Gauge	21 GA
Shank Dia	0.84 mm(0.033")
Fastener Range	12~50 mm (15/32"~2")
Shank Type	Smooth
Loading Capacity	100 pcs
Working Pressure	5~7 bar/70~100 psi

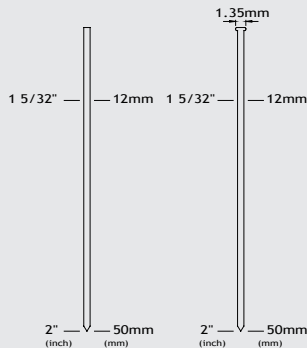

23GA. \varnothing 0.84mm



APPLICATION

- Light wood assy
- Finish and trim work
- Decorative trim
- Dowel and joint pinning
- Mirror and picture frame assy
- Glazing slips
- Craft work
- Paneling external softwood trim
- Wall framing
- Truss construction
- Roofing
- Rettan furniture
- Window beading
- Display and sign work

FEATURES

- Drives headless pins and small head brads
- Rear exhaust with Silence
- The patented adjust-free magazine for easy using any fastener length
- Double trigger safety lock helps prevent accidental firing of the tool
- Removable nose cover provides easy access to clear fastener jams
- A narrow nose on the pinners allows the tool to reach into tight areas, and detailed work surfaces
- The storage area provides easy access to your no-mar rubber tip and hex wrench used for removing the nose plate
- Auto Lock-out prevents dry-firing of the tool
- The belt hook provides easy carrying of the tool
- The window on the magazine can show if fasteners are low and when reloading is necessary
- A manual override button allows the last several pins to be driven if necessary
- The rear of the magazine is cut-off at an angle to allow the tool to be placed right up to the corner
- Rubber grip for comfort usage

RPT840F 21GA. 2 IN 1 Pin Nailer With Front Exhaust



L x W x H	250x43x200 mm
Weight	1.2 kgs
Gauge	21 GA
Shank Dia	0.84 mm(0.033")
Fastener Range	12~40 mm (1-5/32"~1-9/16")
Shank Type	Smooth
Loading Capacity	100 pcs
Working Pressure	5~7 bar/70~100 psi

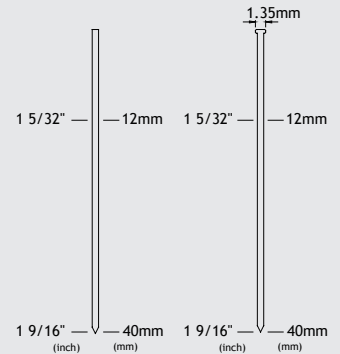

APPLICATION

- Light wood assy
- Finish and trim work
- Decorative trim
- Dowel and joint pinning
- Mirror and picture frame assy
- Glazing strips
- Craft work
- Paneling external softwood trim
- Wall framing
- Truss construction
- Roofing
- Rettan furniture
- Window beading
- Display and sign work

FEATURES

- Drives headless pins and micro head brads
- Front exhaust
- The patented adjust-free magazine for easy using any fastener length
- Double trigger safety lock helps prevent accidental firing of the tool
- Removable Nose Cover provides easy access to clear fastener jams
- A narrow nose on the pinner allows the tool to reach into tight areas, and detailed work surfaces
- The window on the magazine can show if fasteners are low and when reloading is necessary
- Rubber grip for comfort usage

RPT830FL

21GA. 2 In 1 Pin Nailer With Extended Magazine and Front Exhaust

L x W x H	265x40x175 mm
Weight	1.06 kgs
Gauge	21 GA
Shank Dia	0.84 mm(0.033")
Fastener Range	12~30 mm (1-5/32"~1-16")
Shank Type	Smooth
Loading Capacity	140 pcs
Working Pressure	5~7 bar/70~100 psi

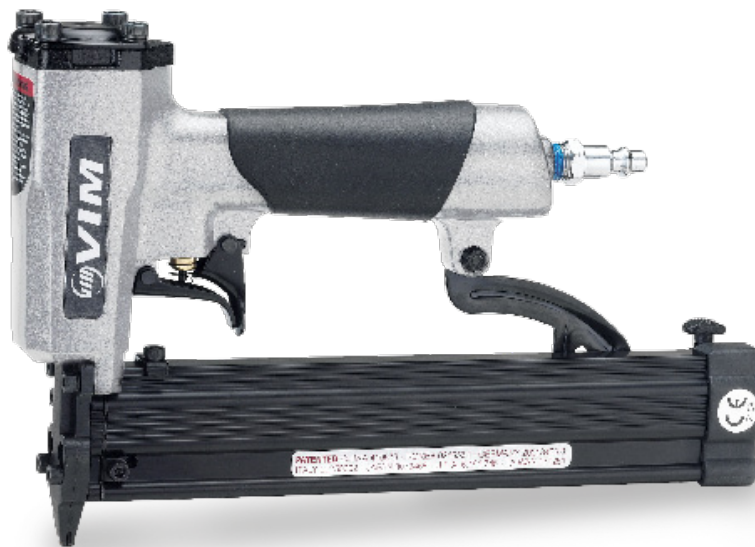
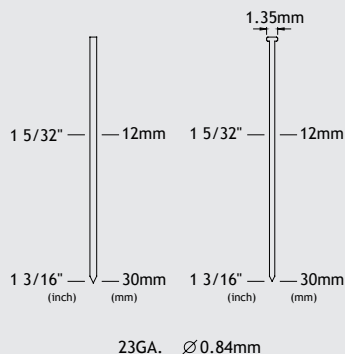

APPLICATION

- Light wood assy
- Finish and trim work
- Decorative trim
- Dowel and joint pinning
- Mirror and picture frame assy
- Glazing strips
- Craft work
- Paneling external softwood trim
- Wall framing
- Truss construction
- Roofing
- Rettan furniture
- Window beading
- Display and sign work

FEATURES

- Drives headless pins and small head brads
- Rear exhaust with silence
- Extended Magazine for loading more nails
- The patented adjust-free magazine for easy using any fastener length
- Double trigger safety lock helps prevent accidental firing of the tool
- Removable nose cover provides easy access to clear fastener jams
- A narrow nose on the pinners allows the tool to reach into tight areas, and detailed work surfaces
- Removable no-mar rubber tip protect your work surface
- The belt hook provides easy carrying of the tool
- The window on the magazine can show if fasteners are low and when reloading is necessary
- The rear of the magazine is cut-off at an angle to allow the tool to be placed right up to the corner
- Rubber grip for comfort usage
- Bigger loading capacity to save your time from reloading pins (200 pcs)
- Plastic end core on magazine for easy and comfort usage

RPT630R

23GA. 2 IN 1 Pin Nailer With Rear Exhaust



L x W x H	175x40x220 mm
Weight	1.02 kgs
Gauge	23 GA
Shank Dia	0.64 mm(0.025")
Fastener Range	12~30 mm (1-5/32"~1-3/16")
Shank Type	Smooth
Loading Capacity	100 pcs
Working Pressure	5~7 bar/70~100 psi

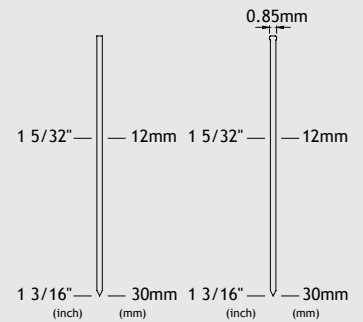

23GA. \varnothing 0.64mm

APPLICATION

- Light wood assy
- Finish and trim work
- Decorative trim
- Dowel and joint pinning
- Mirror and picture frame assy
- Glazing strips
- Craft work
- Paneling external softwood trim
- Wall framing
- Truss construction
- Roofing
- Rettan furniture
- Window beading
- Display and sign work

FEATURES

- Drives headless pins and micro head brads
- Rear exhaust conveniently directs exhaust away from user and work surface
- The patented adjust-free magazine for easy using any fastener length
- Double trigger safety lock helps prevent accidental firing of the tool
- Removable nose cover provides easy access to clear fastener jams
- A narrow nose on the pinners allows the tool to reach into tight areas, and detailed work surfaces
- The belt hook provides easy carrying of the tool
- The window on the magazine can show if fasteners are low and when reloading is necessary
- Rear exhaust with silence
- The rear of the magazine is cut-off at an angle to allow the tool to be placed right up to the coner
- Rubber grip for comfort usage
- Drives headless pins and small head brads

65

FASTENING A DIFFERENCE

RPT635R

23GA. 2 IN 1 Pin Nailer With Rear Exhaust Drywall & Steel plate is available

L x W x H	220x58x188 mm
Weight	0.92 kgs
Gauge	23 GA
Shank Dia	0.64 mm(0.025")
Fastener Range	12~35 mm (1-5/32"~1-3/8")
Shank Type	Smooth
Loading Capacity	100 pcs
Working Pressure	5~7 bar/70~100 psi

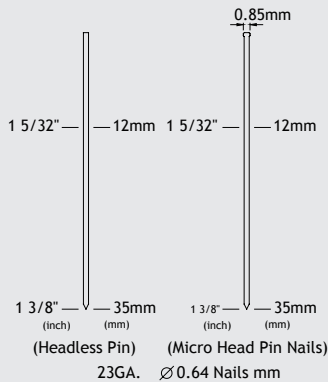

APPLICATION

- Light wood assy
- Finish and trim work
- Decorative trim
- Dowel and joint pinning
- Mirror and picture frame assy
- Glazing strips
- Craft work
- Paneling external softwood trim
- Wall framing
- Truss construction
- Roofing
- Rettan furniture
- Window beading
- Display and sign work

FEATURES

- Drives headless pins and micro head brads
- The patented adjust-free magazine for easy using any fastener length
- Double trigger safety lock helps prevent accidental firing of the tool
- Removable nose cover provides easy access to clear fastener jams
- A narrow nose on the pinner allows the tool to reach into tight areas, and detailed work surfaces
- The window on the magazine can show if fasteners are low and when reloading is necessary
- Rubber grip for comfort usage
- Rear Exhaust with Silence
- Plastic end core on magazine for easy and comfort usage
- Convenient belt hook for easy carrying of tool
- Quick access magazine storage for wrench and no-mar rubber tip
- Powerful motor penetrates through the hardest,hardest materials
- Compact and lightweight design for improved maneuverabilit
- Side loading with mechanism to prevent fasteners form tumbling
- Removable no-mar tip prevents marring of worl surface

RPT650R 23GA. 2 IN 1 Pin Nailer With Rear Exhaust



L x W x H	230x65x225 mm
Weight	1.24 kgs
Shank Dia	23 GA
Gauge	0.64 mm(0.025")
Fastener Range	12~50 mm (1-5/32"~2")
Shank Type	Smooth
Load Capacity	100 pcs
Operating Pressure	5~7 bar/70~100 psi

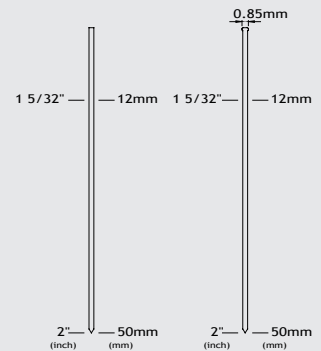

APPLICATION

- Light wood assy
- Finish and trim work
- Decorative trim
- Dowel and joint pinning
- Mirror and picture frame assy
- Glazing strips
- Craft work
- Paneling external softwood trim
- Wall framing
- Truss construction
- Roofing
- Rettan furniture
- Window beading
- Display and sign work

FEATURES

- Drives headless pins and micro head brads
- Rear exhaust with silence
- The patented adjust-free magazine for easy using any fastener length
- A narrow nose on the pinner allows the tool to reach into tight areas, and detailed work surfaces
- Removable no-mar rubber tip protect your work surface
- The storage area provides easy access to your no-mar rubber tip and hex wrench used for removing the nose plate
- Auto lock-out prevents dry-firing of the tool
- The belt hook provides easy carrying of the tool
- The window on the magazine can show if fasteners are low and when reloading is necessary
- A manual override button allows the last several pins to be driven if necessary
- The rear of the magazine is cut-off at an angle to allow the tool to be placed right up to the corner
- Rubber grip for comfort usage

V15AA Corrugated Nailer

L x W x H	516x394x110 mm(L magazine)
Weight	2.75 kgs
Crown	17 mm
Length of Fastener	9mm, 12mm, 15mm
Operating Pressure	100~120psi
Loading Capacity	100 nails

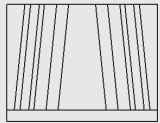
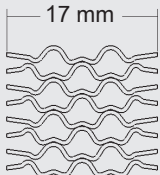

FEATURES

- Easy bottom loading magazine
- Easy magazine adjustment without any tools
- Less surface mark on the work piece
- 360 adjustable exhaust cover
- Single contact trigger
- Bottom loading magazine

APPLICATION

- Picture
- Mirror
- Door
- Window frames assembly

CF25S Corrugated Nailer



L x W x H	280x85x290 mm
Weight	2.75 kgs
Crown	25.4 mm
Length of Fastener	9mm, 12mm, 15mm
Operating Pressure	100~120psi
Loading Capacity	100 nails

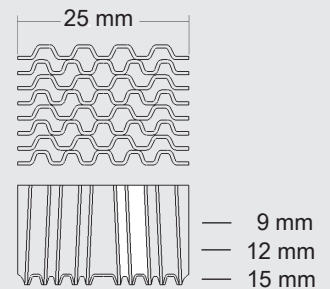

FEATURES

- Perfect balance and light weight
- High power for hard wood applications
- 360 adjustable exhaust cover
- Slide-in insert to adjust the different lengths of fasteners
- Fasteners for CF25S equivalent to fasteners for Senco, Ni the operator kema, Atro, Haubold, Spotnails
- Anti-double shot mechanism
- Profiled Nose and extended driver to work on corner joints
- Alumin alloy housing
- Bottom loading magazine
- Single contact trigger

APPLICATION

- Picture
- Mirror
- Door
- Window frames assembly

CF25P Corrugated Nailer

L x W x H	280x85x290 mm
Weight	2.75 kgs
Crown	25 mm
Length of Fastener	9mm, 12mm, 15mm
Operating Pressure	100~120psi
Loading Capacity	100 nails

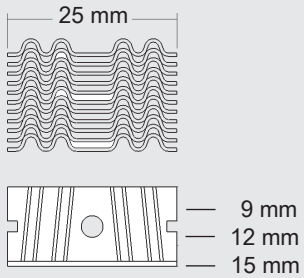

FEATURES

- Perfect balance and light weight
- High power for hard wood applications
- 360 adjustable exhaust cover
- Slide-in insert to adjust the different lengths of fasteners
- Anti-double shot mechanism
- Profiled Nose and extended driver to work on corner joints
- Fasteners for CF25P equivalent to Paslode GC-20
- Single contact trigger
- Bottom loading magazine

APPLICATION

- Picture
- Mirror
- Door
- Window frames assembly

CF175 Corrugated Nailer



FEATURES

- Perfect balance and light weight
- High power for hard wood applications
- 360 adjustable exhaust cover
- Slide-in insert to adjust the different lengths of fasteners
- Anti-double shot mechanism
- Profiled Nose and extended driver to work on corner joints
- Fasteners for CF25P equivalent to Paslode GC-20
- Single contact trigger
- Bottom loading magazine

APPLICATION

- Picture
- Mirror
- Door
- Window frames assembly

L x W x H	
Weight	2.75 kgs
Crown	
Length of Fastener	9mm, 12mm, 15mm
Operating Pressure	
Loading Capacity	

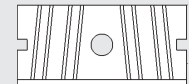
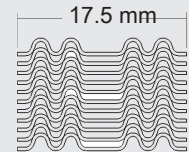

— 9 mm
— 12 mm
— 15 mm

8025 21GA STAPLER

L x W x H	215x55x180 mm
Weight	1.2 kgs
Operating Pressure	70 psi~110psi
Gauge	21 GA
Crown	12.9 mm
Loading Capacity	100 pcs
Staple Size	0.64x0.95 mm
Fastener Range	25 mm

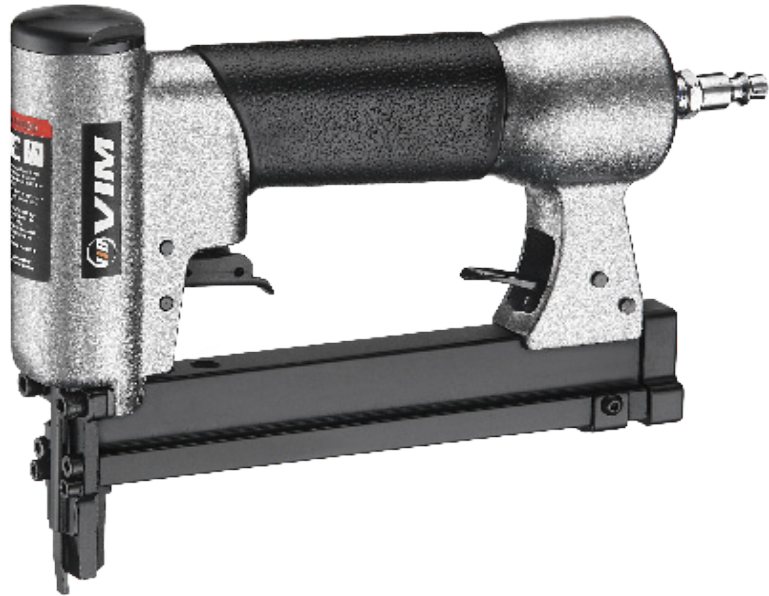

FEATURES

- Compact Tool Design-Less parts.
- Compact Size
- Light weight(lightest in the world),1.2 Kgs
- One hand manual rear latch for easy loading
- Rear air Exhaust,Anti dirt on work plese
- Repaid Trigger valve 20 shoots/Second
- Single / Auto shoot adjustable(From 1to 20)
- Low air consumption(Save 30 to 40% compare with competitor)
- Durable Drive unit and Bumper

APPLICATION

- Furniture
- Upholstering
- Automotive Vinyl
- Interior Trim
- House Decoration

8016A,5016A,7116A,1013JA,1013FA,A1116A,8416A,6416A,413JA,SNCA16A,SJK16A UPHOLSTERY STAPLERS,AUTO FIRING



L x W x H/STANDARD	216x140x38 mm
Weight	0.9kgs
Operating Pressure	5~7 bar / 70~110 psi

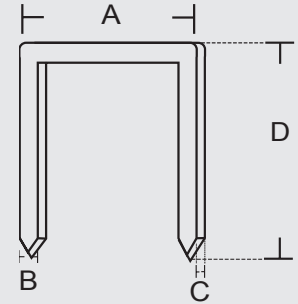

Spec Model no	CROWN (A)	WIDTA (B&C)	GAUGE	FASTENER RANGE (D)	LOADING CAPAITY (PCS)
5016A	12.6 mm	0.5 x 1.25	20 GA	5 - 16	220
7116A	9.1 mm	0.6 x 0.75	22 GA	5 - 16	400
8016A	12.9 mm	0.65 x 0.95	21 GA	5 - 16	270
1013JA	11.2 mm	0.6 x 1.2	20 GA	5 - 16	220
1013FA	11.2 mm	0.5 x 0.7	23 GA	5 - 16	400
A1116A	9.5 mm	0.5 x 1.3	21 GA	5 - 16	220
8416A	12.3 mm	0.55 x 1	21 GA	5 - 16	220
6416A	12.5 mm	0.55 x 0.75	22 GA	5 - 16	400
413JA	5.2 mm	0.6 x 1.2	20 GA	5 - 16	220
SNCA16A	4.7 mm	0.6 x 0.75	22 GA	5 - 16	400
SJK16A	4.1 mm	0.6 x 0.75	22 GA	5 - 16	400

APPLICATION

- Furniture
- Upholstering
- Automotive Vinyl
- Interior
- Trim
- House Decoration
- Carpet Edge

FEATURES

- Patent One hand manual rear latch(easy loading)
- Compact Tool Design-Less parts.
- Powerful(Rapid Shooting up to16mm)
- The shortest fastener 3mm can be shot without tumbling
- Rear air Exhaust / Anti dirt on work piece
- Low air consumption(Save 30 to 40% compare with competitor)
- Durable Drive Unit and Bumper

8016ALM,5016ALM,7116ALM,1013ALM,1013FALM,A1116ALM, 8416ALM,6416ALM,413JALM,SNCA16ALM,SJK16ALM UPHOLSTERY STAPLERS WITH AUTO FIRING AND LONG MAGAZINE

L x W x H	380x140x38 mm
Weight	1.2 kgs
Working Pressure	5-7 bar/70-100 psi

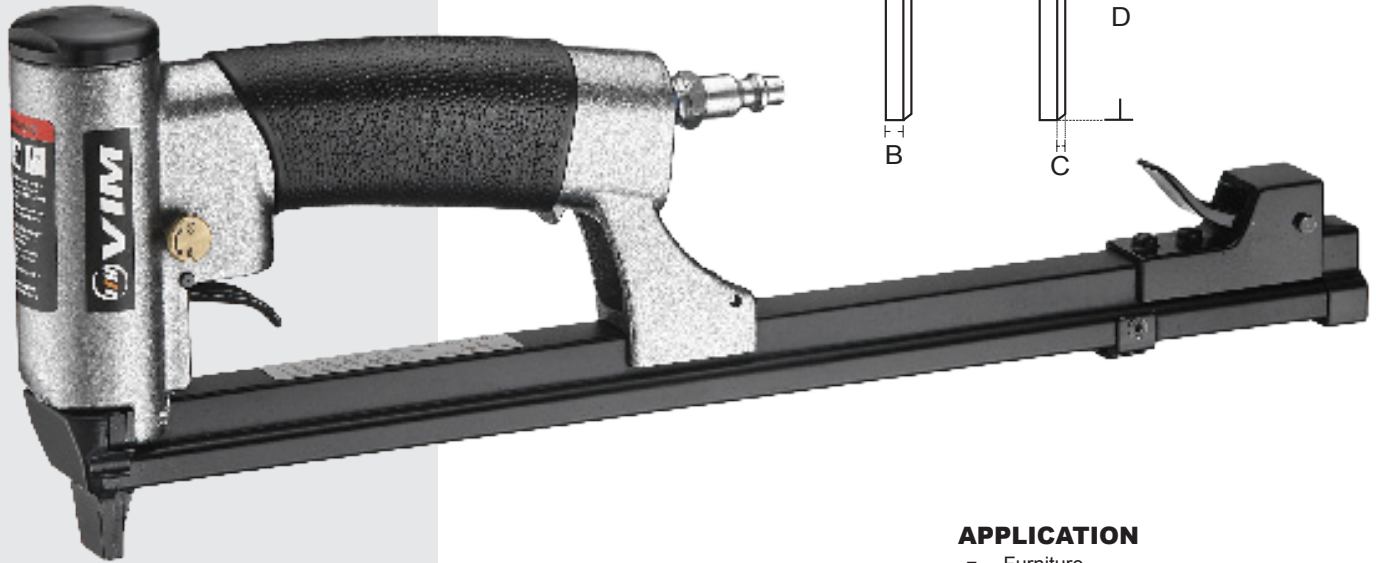
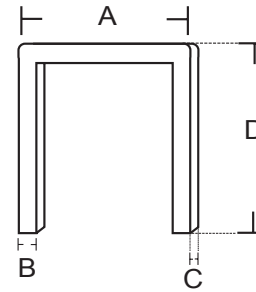

APPLICATION

- Furniture
- Upholstering
- Automotive Vinyl
- Interior Trim
- House Decoration

Spec Model no	CROWN (A)	WIDTA (B&C)	GAUGE	FASTENER RANGE (D)	LOADING CAPACITY (PCS)
5016ALM	12.6 mm	0.5 x 1.25	20 GA	5 - 16	220
7116ALM	9.1 mm	0.6 x 0.75	22 GA	5 - 16	400
8016ALM	12.9 mm	0.65 x 0.95	21 GA	5 - 16	270
1013JALM	11.2 mm	0.6 x 1.2	20 GA	5 - 16	220
1013FALM	11.2 mm	0.5 x 0.7	23 GA	5 - 16	400
A1116ALM	9.5 mm	0.5 x 1.3	21 GA	5 - 16	220
8416ALM	12.3 mm	0.55 x 1	21 GA	5 - 16	220
6416ALM	12.5 mm	0.55 x 0.75	22 GA	5 - 16	400
413JALM	5.2 mm	0.6 x 1.2	20 GA	5 - 16	220
SNCA16ALM	4.7 mm	0.6 x 0.75	22 GA	5 - 16	400
SJK16ALM	4.1 mm	0.6 x 0.75	22 GA	5 - 16	400

FEATURES

- Patent Rapid Trigger valve
(20 shoots/Second)
- Patent One hand manual rear latch (easy loading)
- Compact Tool Design-Less parts.
- Rear air Exhaust / Anti dirt on work piese
- Single / Auto shoot adjustable (From 1to 20 shots Per Second)
- Low air consumption (Save 30 to 40% compare with competitor)
- Durable Drive unit and Bumper

8016S,5016S,7116S,1013JS,1013FS,A1116S,8416S,6416S,413JS,SNCA16S,SJK16S UPHOLSTERY STAPLERS,SINGLE FIRING



STANDARD NOSE AND MAGAZINE

L x W x H	216x140x38 mm
Weight	0.9kgs
Operating Pressure	5-7 bar / 70-110 psi

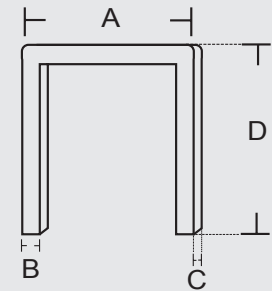

APPLICATION

- Furniture
- Upholstering
- Automotive Vinyl
- Interior
- Trim
- House Decoration
- Carpet Edge

FEATURES

- Compact Tool Design-Less parts.
- Powerful(Rapid Shooting up to 16mm)
- The shortest fastener 3mm can be shut without tumbling
- Compact Size
- Light weight
- One hand manual rear latch(easy loading)
- Rear air Exhaust / Anti dirt on work piece
- Low air consumption(Save 30 to 40% compare with competitor)
- Durable Drive unit and Bumper

Model no	Spec	CROWN (A)	WIDTA (B&C)	GAUGE	FASTENER RANGE (D)	LOADING CAPAITY (PCS)
5016S		12.6 mm	0.5 x 1.25	20 GA	5 - 16	100
7116S		9.1 mm	0.6 x 0.75	22 GA	5 - 16	150
8016S		12.9 mm	0.65 x 0.95	21 GA	5 - 16	100
1013JS		11.2 mm	0.6 x 1.2	20 GA	5 - 16	100
1013FS		11.2 mm	0.5 x 0.7	23 GA	5 - 16	150
A1116S		9.5 mm	0.5 x 1.3	21 GA	5 - 16	100
8416S		12.3 mm	0.55 x 1	21 GA	5 - 16	100
6416S		12.5 mm	0.55 x 0.75	22 GA	5 - 16	150
413JS		5.2 mm	0.6 x 1.2	20 GA	5 - 16	100
SNCA16S		4.7 mm	0.6 x 0.75	22 GA	5 - 16	150
SJK16S		4.1 mm	0.6 x 0.75	22 GA	5 - 16	150

75

FASTENING A DIFFERENCE

8016LNM,5016LNM,7116LNM,1013FLNM,1013JLNM,A1116LNM,SNCG16LNM UPHOLSTERY STAPLERS WITH LONG NOSE AND LONG MAGAZINE

L x W x H/STANDARD	380x197x38 mm
Weight	1.25kgs
Operating Pressure	5-7 bar / 70-110 psi
Magazine Capacity	100 staples

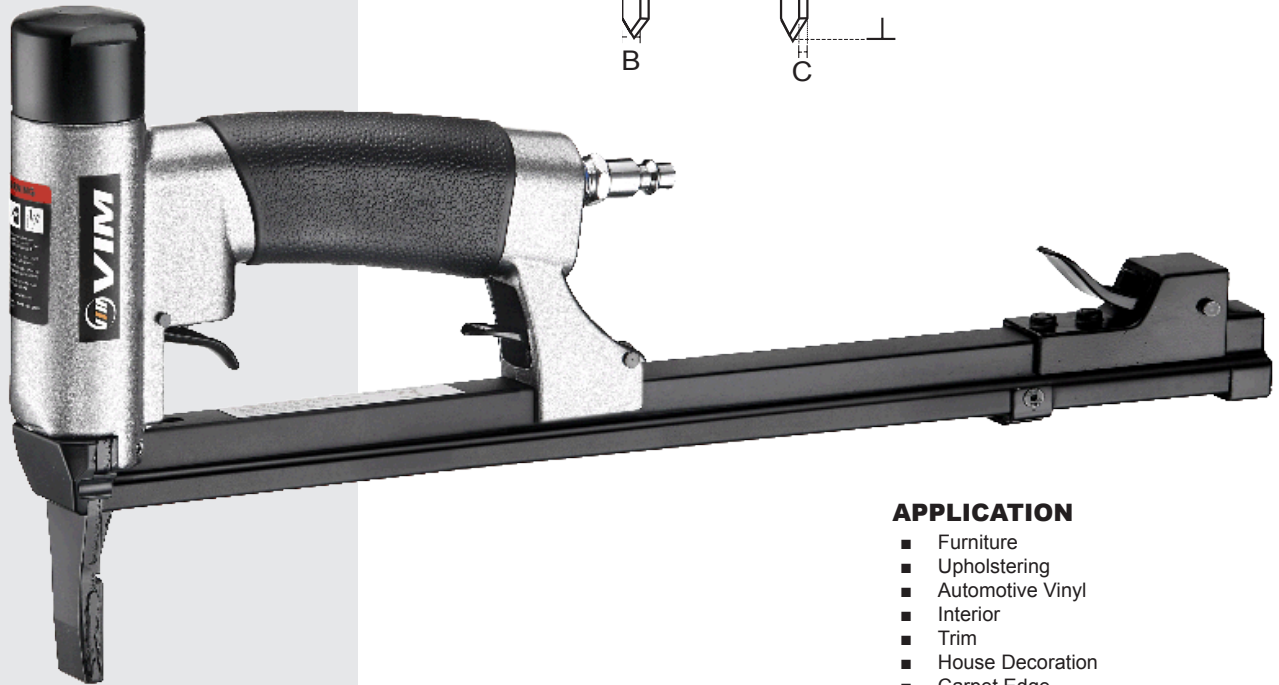
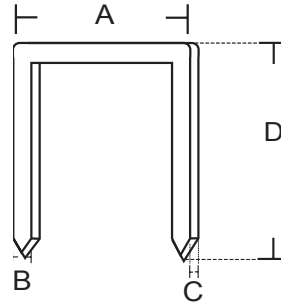

APPLICATION

- Furniture
- Upholstering
- Automotive Vinyl
- Interior
- Trim
- House Decoration
- Carpet Edge

FEATURES

- Patent One hand manual rear latch(easy loading)
- Compact Tool Design-Less parts.
- Powerful(Rapid Shooting up to16mm)
- The shortest fastener 3mm can be shot without tumbling
- Rear air Exhaust / Anti dirt on work piece
- Low air consumption(Save 30 to 40% compare with competitor)
- Durable Drive Unit and Bumper

Spec Model no	CROWN (A)	WIDTA (B&C)	GAUGE	FASTENER RANGE (D)	LOADING CAPAITY (PCS)
5016LNM	12.6 mm	0.5 x 1.25	20 GA	5 - 16	220
7116LNM	9.1 mm	0.6 x 0.75	22 GA	5 - 16	400
8016LNM	12.9 mm	0.65 x 0.95	21 GA	5 - 16	270
1013JLNM	11.2 mm	0.6 x 1.2	20 GA	5 - 16	220
1013FLNM	11.2 mm	0.5 x 0.7	23 GA	5 - 16	400
A1116LNM	9.5 mm	0.5 x 1.3	21 GA	5 - 16	220
SNCA16LNM	4.7 mm	0.6 x 0.75	22 GA	5 - 16	400

8016SLN,5016SLN,7116SLN,1013FSLN,1013JSLN,A1116SLN,SNCG16SLN WITH LONG NOSE,SINGLE FIRING UPHOLSTERY STAPLER



L x W x H	216x197x38 mm
Weight	0.9kgs
Operating Pressure	5~7 bar / 70~110 psi

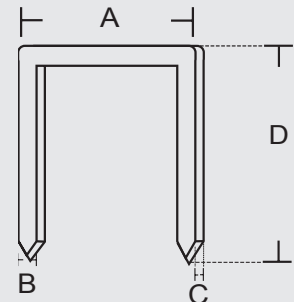

APPLICATION

- Furniture
- Upholstering
- Automotive Vinyl
- Interior
- Trim
- House Decoration
- Carpet Edge

FEATURES

- Patent One hand manual rear latch(easy loading)
- Compact Tool Design-Less parts.
- Powerful(Rapid Shooting up to16mm)
- The shortest fastener 3mm can be shot without tumbling
- Rear air Exhaust / Anti dirt on work piec e
- Low air consumption(Save 30 to 40% compare with competitor)
- Durable Drive Unit and Bumper

Model no	Spec	CROWN (A)	WIDTA (B&C)	GAUGE	FASTENER RANGE (D)	LOADING CAPAITY (PCS)
5016SLN		12.6 mm	0.5 x 1.25	20 GA	5 - 16	220
7116SLN		9.1 mm	0.6 x 0.75	22 GA	5 - 16	400
8016SLN		12.9 mm	0.65 x 0.95	21 GA	5 - 16	270
1013JSLN		11.2 mm	0.6 x 1.2	20 GA	5 - 16	220
1013FSLN		11.2 mm	0.5 x 0.7	23 GA	5 - 16	400
A1116SLN		9.5 mm	0.5 x 1.3	21 GA	5 - 16	220

SP635 23 GA. HEADLESS & MICRO HEAD 2 IN 1 PIN NAILER

L x W x H	205x35x176 mm
Weight	0.8 kgs
Nail Capacity	120 pins
Working Pressure	5-7 bar/70~100 psi
Gauge	23 GA
Operating Pressure	120 psi
Shank Dia	0.64 mm(0.025")
Fastener Range	12~30 mm

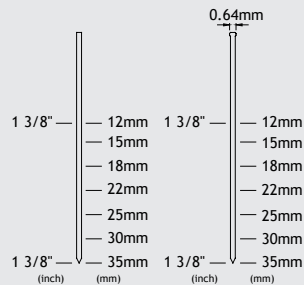

23GA. Ø0.64mm



APPLICATION

- Furniture
- Upholstering
- Automotive Vinyl
- Interior
- Trim
- House Decoration
- Carpet Edge
- Staple Removal

FEATURES

- Drives both headless pin and micro head brads
- Compact Size
- Low air consumption
- Durable Bumper - over 500,000 Shoots
- Durable Drive Blade - over 200,000 Shoots
- Light weight Only 0.82kgs
- Adjust Free Magazine/No need to adjust magazine for different length Pins
- Magazine Angle rear-For easy using on the piece
- Contact Safety With Lock out system (7 pins)/Anti Dry Fire System
- Transparent Magazine - Allow to see left Pins
- Safety With driving depth adjustmen.(safety system)
- Safety With No Mar Tip / no Scrap on work piece
- Narrow Nose Design - To reach the narrow space
- Belt Hook
- Depth Control Adjustment
- Anti - Dry Fire Mechanism

6816 23GA. FINE WIRE STAPLER



L x W x H	216x148x43 mm
Weight	0.9 kgs
Loading Capacity	185 staples
Gauge	23 GA
Crown	9.5 mm
Fastener Range	4~16 mm
Operating Pressure	60-90 psi
Width x Thickness	0.55x0.75 mm

APPLICATION

- Upholstery
- Automotive trim
- Insulation
- Cabinet backs
- Small furniture
- Picture frames
- Light trim and moulding
- Reinforce construction
- Tectonic floor
- Drywall and partition
- Steel to concrete
- Steel to steel

FEATURES

- Comfortable handle with rubber
- Strong and light weight die cast housing
- Fast and easy down loading

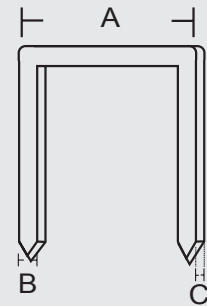

Spec Model no	CROWN (A)	WIDTH (B&C)	GAUGE
8016	12.7 mm	0.6 x 0.9 mm	21 GA
81P	12.7 mm	1.1 x 1.25 mm	19GA
82P	12.7 mm	0.6 x 0.9 mm	16GA
1013J	11.2 mm	0.6 x 1.20 mm	20GA
1013F	11.2 mm	0.5 x 0.7 mm	22GA

NK440QF Flooring Stapler

L x W x H	254x235x58 mm
Weight	1.2 kgs
Load Capacity	150 staples
Operating Pressure	70-100psi
Gauge	18
Crown	6.4mm(0.25")
Width x Thickness	1.25mm x 1.00mm
Fastener Range	13mm(1/2")-40mm(1-5/8")

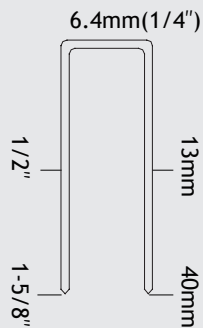

APPLICATION

- Furniture and Wooden cases manufacturers, Floor, Decoration and other kinds of fastening work
- Flooring

FEATURES

- Lightweight design prevents arm fatigue
- Ergonomic comfort handgrip provides a firm grip for user
- Depth of drive dial allows convenient and precise staple settings
- Quick release nose cover provides easy access for clearing jams
- Powerful penetration through the toughest materials
- High fastener capacity reduces frequency for reloading
- Durable driver and piston o-ring assembly
- Convenient side loading for quick fastener reloading
- 360° adjustable exhaust cover
- Aiming accurately at 50° of the floor
- Adjustable safety
- Equivalent to Omer/Atro 90 staple

1664TA 16 Ga Angled Brad Nailer



L x W x H	344x84x308 mm
Weight	4.6 lbs
Hesd	0.126"(3.2mm)
Load Capacity	110 nails
Shank Diameter	0.072"(1.83mm)
Gauge	15
Nail Length	1 1/4"-2 1/2" (32mm-64mm)

32mm	—	1-1/4"
38mm	—	1-1/2"
45mm	—	1-3/4"
50mm	—	2"
57mm	—	2-1/4"
64mm	—	2-1/2"

FEATURES

- Swivel exhaust deflector
- Switchable trigger
- Quick jam release
- Adjustable nail depth control
- No-Mar pad
- Bypass nail pusher
- Rubber grip for comfort

APPLICATION

- Light Framing
- Interior / Exterior finish and trim
- Decoration
- Furniture frame assembly
- Cabinet work
- Door and window construction

RT635RS 23GA. 2 IN 1 PIN NAILER

L x W x H	197x171x38 mm
Weight	9.5 kgs
Gauge	23 GA
Shank Dia	0.64mm
Fastener Range	12mm~35mm
Operating Pressure	70-100psi
Loading Capacity	100pcs

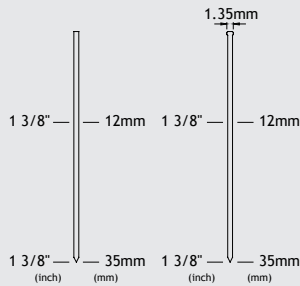

23GA. \varnothing 0.64mm



APPLICATION

- Light wood assy
- Finish and trim work
- Decorative trim
- Dowel and joint pinning
- Mirror and picture frame assy
- Paneling external softwood trim
- Wall framing
- Truss construction

FEATURES

- Drives headless pins and micro head brads
- Automatic adjust magazine in changing different length of pins
- Double trigger safety lock helps prevent accidental firing of the tool
- Removable nose cover provides easy access to workpiece
- A narrow nose on the pinners allows the tool to reach into tight areas, and detailed work surfaces
- The view window on the magazine can show if fasteners are low and when reloading is necessary
- Rubber grip for comfort usage
- Rear Exhaust with Silencer

RT650S 23GA. 2 IN 1 PIN NAILER



L x W x H	197x225x38 mm
Weight	1 kgs
Gauge	23 GA
Shank Dia	0.64mm
Fastener Range	12mm~50mm
Operating Pressure	70-100psi

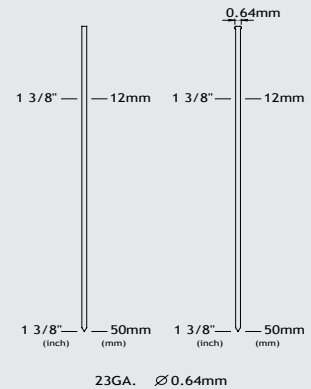

FEATURES

- Drives headless pins and micro head brads
- Automatic adjust magazine in changing different length of pins
- Double trigger safety lock helps prevent accidental firing of the tool
- Removable nose cover provides easy access to workpiece
- A narrow nose on the pinner allows the tool to reach into tight areas, and detailed work surfaces
- The view window on the magazine can show if fasteners are low and when reloading is necessary
- Rubber grip for comfort usage
- Rear Exhaust with Silencer

APPLICATION

- Light wood assy
- Finish and trim work
- Decorative trim
- Dowel and joint pinning
- Mirror and picture frame assy
- Paneling external softwood trim
- Wall framing
- Truss construction

SD65 Heavy Duty Concrete Nailer

L x W x H	430x113x430 mm
Weight	5.2 kgs
Length of Pin	15~65mm
Operating Pressure	80-120psi
Nail Dia	2.6~3.0 mm

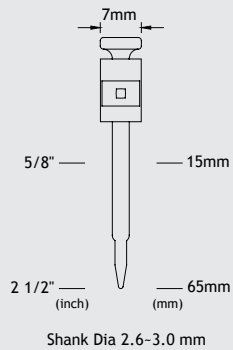

APPLICATION

- Reinforce construction
- Tectonic floor
- Drywall and partition
- Steel to concrete
- Steel to steel
- Wood to concrete

FEATURES

- Use same pins with gas nailer
- Powerful than gas nailer
- 360° Exhaust deflector
- Adjustable safety for pin depth control
- Extra handle bar for easy operation
- Single and Consecutive Fire

A7 16GA.Manual Hog Ring Plier

Size	183x93x26 mm
Weight	316 g
Ring Capacity	50pcs
Gauge	16 GA
Crown	17.4 mm
Closure size	7 mm

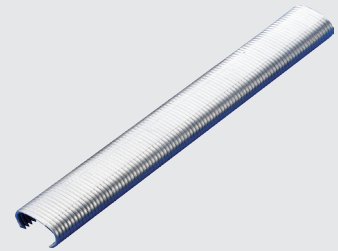
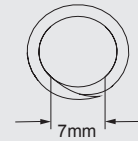
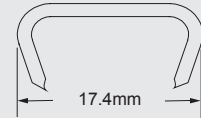

APPLICATION

- Industrial packaging
- Furniture upholstery
- Netting / mech
- Cage repairs
- Arts and crafts
- Fence constructions
- Bag closure

FEATURES

- Automatic feed
- One-hand operation
- Black coated finish
- Anti-slip red handles
- Chrome-plated magazine
- Durable all-steel construction
- Magazine capacity:50pcs

CN130WPA&CN130WPB 16° Wire & Plastic Sheet Coil Nailers

L x W x H	380x113x480 mm
Weight	5.5 kgs
Load Capacity	200-300 nails
Operating Pressure	100-120 psi
Magazine Type	Flat type
Nail Shank	3.3~3.8mm - CN130WPA 2.5~3.8mm - CN130WPB
Head Dia	7.2~8.0mm - CN130WPA 6.0~7.2mm - CN130WPB

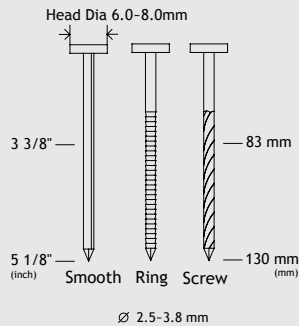

APPLICATION

- Construction work (ex: siding, roofing and sheathing)
- Use for wooden cases
- Light pallets
- Wooden furniture
- Wooden sashes and other wood products
- Reinforce construction
- Tectonic floor
- Drywall and partition
- Steel to concrete
- Steel to steel

FEATURES

- 360 exhaust deflector allows exhaust of air in any direction
- Depth of drive adjustment to countersink or flush drive nails
- Lightweight design prevents arm fatigue for user
- Drives wire and plastic sheet collated nails
- Single fire and consecutive driving of nails
- Alumin Alloy Housing
- Side Loading Magazine

CN100WPA&CN100WPB 16° Wire & Plastic Sheet Coil Nailers



L x W x H	380x113x420 mm
Weight	5 kgs
Load Capacity	200-300 nails
Operating Pressure	100-120 psi
Magazine Type	Flat type
Nail Shank	3.3~3.8mm - CN100WPA 2.5~3.3mm - CN100WPB
Head Dia	7.0~7.5mm - CN100WPA 6.0~7.2mm - CN100WPB

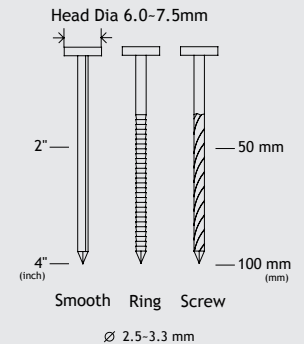

APPLICATION

- Construction work (ex: siding, roofing and sheathing)
- Use for wooden cases
- Light pallets
- Wooden furniture
- Wooden sashes and other wood products
- Reinforce construction
- Tectonic floor
- Drywall and partition
- Steel to concrete
- Steel to steel

FEATURES

- 360 exhaust de flector allows exhaust of air in any direction
- Depth of drive adjustment to countersink or flush drive nails
- Lightweight design prevents arm fatigue for user
- Drives wire and plastic sheet collated nails
- Aluminum Alloy Housing
- Side loading magazine
- Singel fire and consecutive driving of nails

R555PN 15/18

PNEUMATIC TOP CARTON CLOSING STAPLER

L x W x H	235x104x205 mm
Weight	1.78 kgs
Fastener Capacity	1000
Fasteners Length	15&18 mm
Crown	32 mm
Wire Dia	1.9x0.9 mm
Operating Pressure	70 - 120psi



FEATURES

- Use roll type carton staples/Flat type
- One tool for two staple leg lengths
- Capable for staple length 15mm & 18mm
- Aluminum rear cap offer more durability and prevent leak leakage
- 5 positions toolless penetration adjustment
- Staple clinch adjustment for tight and loose clinch
- Magnesium bases benefit more durable and light weight
- Quick jam clearance
- User friendly hanger
- High capacity and easy to load magazine
- Similar to josef kihlberg R555PN

APPLICATION

- Top stapling
- Carton closing

D32/18-B1 PNEUMATIC TOP CARTON CLOSING STAPLER



L x W x H

Weight

Fastener Capacity

Fasteners Length

Crown

Wire Dia

Operating Pressure

FEATURES

- Use roll type carton staples/Flat type
- One tool for two staple leg lengths
- Capable for staple length 15mm & 18mm
- Aluminum rear cap offer more durability and prevent leak leakage
- 5 positions toolless penetration adjustment
- Staple clinch adjustment for tight and loose clinch
- Magnesium bases benefit more durable and light weight
- Quick jam clearance
- User friendly hanger
- High capacity and easy to load magazine
- Similar to josef kihlberg R555PN

APPLICATION

- Top stapling
- Carton closing

D32/18

PNEUMATIC TOP CARTON CLOSING STAPLER

L x W x H	406x103x210 mm
Weight	1.84 kgs
Fastener Capacity	150
Fasteners Length	15&18 mm
Crown	32 mm
Wire Dia	1.9x0.9 mm
Operating Pressure	70 - 120psi



FEATURES

- One tool for two staple leg lengths
- Capable for staple length 15mm & 18mm
- Aluminum rear cap offer more durability and prevent leak leakage
- 5 positions toolless penetration adjustment
- Staple clinch adjustment for tight and loose clinch
- Magnesium bases benefit more durable and light weight
- Hard - wearing steel magazine
- User friendly hanger
- High capacity and easy to load magazine

APPLICATION

- Top stapling
- Carton closing

D35/18 PNEUMATIC TOP CARTON CLOSING STAPLER



L x W x H	406x103x210 mm
Weight	1.84 kgs
Fastener Capacity	150
Fasteners Length	15&18 mm
Crown	35 mm
Wire Dia	2.39x0.9 mm
Operating Pressure	70 - 120psi

FEATURES

- One tool for two staple leg lengths
- Capable for staple length 15mm & 18mm
- Aluminum rear cap offer more durability and prevent leak leakage
- 5 positions toolless penetration adjustment
- Staple clinch adjustment for tight and loose clinch
- Magnesium bases benefit more durable and light weight
- Hard - wearing steel magazine
- User friendly hanger
- High capacity and easy to load magazine

APPLICATION

- Top stapling
- Carton closing

D32/18M

MANUAL TOP CARTON CLOSING STAPLER

L x W x H	455x104x320 mm
Weight	1.64 kgs
Fastener Capacity	150
Fasteners Length	15&18 mm
Crown	32 mm
Wire Dia	1.9x0.9 mm



FEATURES

- One tool for two staple leg lengths
- Capable for staple length 15mm & 18mm
- Aluminum rear cap offer more durability and prevent leak leakage
- 5 positions toolless penetration adjustment
- Staple clinch adjustment for tight and loose clinch
- Magnesium bases benefit more durable and light weight
- Hard - wearing steel magazine
- User friendly hanger
- High capacity and easy to load magazine

APPLICATION

- Top stapling
- Carton closing

D35/18M MANUAL TOP CARTON CLOSING STAPLER



L x W x H	455x104x320 mm
Weight	1.64 kgs
Fastener Capacity	150
Fasteners Length	15&18 mm
Crown	35 mm
Wire Dia	2.39x0.9 mm

FEATURES

- One tool for two staple leg lengths
- Capable for staple length 15mm & 18mm
- Aluminum rear cap offer more durability and prevent leak leakage
- 5 positions toolless penetration adjustment
- Staple clinch adjustment for tight and loose clinch
- Magnesium bases benefit more durable and light weight
- Hard - wearing steel magazine
- User friendly hanger
- High capacity and easy to load magazine

APPLICATION

- Top stapling
- Carton closing

D555/18R

PNEUMATIC TOP CARTON CLOSING STAPLER

L x W x H	235x104x205 mm
Weight	1.78 kgs
Fastener Capacity	1000
Fasteners Length	15&18 mm
Crown	32 mm
Wire Dia	1.9x0.9 mm
Operating Pressure	70 - 120psi



FEATURES

- One tool for two staple leg lengths
- Capable for staple length 15mm & 18mm
- Aluminum rear cap offer more durability and prevent leak leakage
- 5 positions toolless penetration adjustment
- Staple clinch adjustment for tight and loose clinch
- Magnesium bases benefit more durable and light weight
- Hard - wearing steel magazine
- User friendly hanger
- High capacity and easy to load magazine

APPLICATION

- Top stapling
- Carton closing

D35/18M MANUAL TOP CARTON CLOSING STAPLER

L x W x H	455x104x320 mm
Weight	1.64 kgs
Fastener Capacity	150
Fasteners Length	15&18 mm
Crown	35 mm
Wire Dia	2.39x0.9 mm

FEATURES

- One tool for two staple leg lengths
- Capable for staple length 15mm & 18mm
- Aluminum rear cap offer more durability and prevent leak leakage
- 5 positions toolless penetration adjustment
- Staple clinch adjustment for tight and loose clinch
- Magnesium bases benefit more durable and light weight
- Hard - wearing steel magazine
- User friendly hanger
- High capacity and easy to load magazine

APPLICATION

- Top stapling
- Carton closing

MS1619D/MS1619S Mattress Stapler

MS1619D Double Shooting Type

L x W x H	455x45x900 mm
Weight	3 kgs
Gauge	16 GA
Staples Crown	9.5 mm(3/8")
Shank Dia	1.20 mm(0.50")
Fastener Range	19mm(3/4")
Air Consumptio/90ps	0.7 cfm
Cycle Rate	4-6 staples/second
Loading Capacity	100 pcs
Working Pressure	70-120 psi

MS1619S Single Shooting Type

L x W x H	455x45x900 mm
Weight	3 kgs
Gauge	16 GA
Staples Crown	9.5 mm(3/8")
Shank Dia	1.20 mm(0.50")
Fastener Range	19mm(3/4")
Air Consumptio/90ps	0.7 cfm
Cycle Rate	4-6 staples/second
Loading Capacity	100 pcs
Working Pressure	70-120 psi

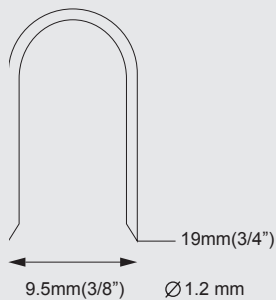

APPLICATION

- Attaching spring to box frame

FEATURES

- Pneumatic stapler for driving staples
- into hard to reach places such as
- bottoms of coil springs
- Available in double staple fire version

D450 Powder Actuated Tool



L x W x H	350x55x180 mm
Weight	3.2 kgs
Cartridge	6.8/11m Black Red · Yellow · Green

APPLICATION

- Wood and metal to concrete or steel
- Electrical installations (switchboxes)
- Clips, clamps and rings for electric cables, conduits and pipes
- Mouldings brackets, sections etc
- General and special contractors
- Plant maintenance
- Woodworking, electrical installation
- Mechanical installation (plumbing, heating and air conditioning)
- Interior finishing
- Plastering

FEATURES

- This powder-actuated tool has a report silencer, power regulation and automatic cartridge feed
- It is suitable for a wide range of fastenings to steel, concrete and hard masonry
- With this piston tool, fasteners cannot ricochet or be shot through walls.
- In addition, contact, drop firing and loading safety devices ensure absolute safety for the operator
- Supplied in a tough plastic tool box with safety and cleaning equipment in the standard kit

VARIOUS PISTONS ARE AVAILABLE



1/4" PISTON

TB PISTON

NK PISTON

GCN2640H Gas Framing Nailer



L x W x H	455x388x110 mm
Weight	3.5 kgs
Loading Capacity	45pcs
Diameter	Ø 2.6~3.0 mm
Battery Capacity	4000 nails per charge
Fastener Range	Shank 15~40 mm
Nail Dia	2.5~3.0 mm



APPLICATION

- Framing
- Sheathing
- Siding
- Trusses
- Bridging
- Wood to masonry
- Engineered lumber
- Fencing
- Exterior decks

FEATURES

- Portable and convenient operation
- Super strength for plastic collated concrete nails
- Light weight and well balanced
- Anti-dry fire mechanism
- Improved air filter effectively prevent dust
- Collapsible reversible rafter hook
- Low battery & high temperature indicator light
- Full sequential actuation
- Patented structure for easy cleaning, repairing and maintenance

GFN2190 Gas Framing Nailer

L x W x H	516x394x110 mm(L magazine) 404x394x110 mm(S magazine)
Weight	3.6 kgs
Loading Capacity	50 pcs(L) 35pcs(S)
Diameter	Ø 2.87~3.33 mm
Battery Capacity	4000 nails
Battery Type	Ni-Mh 7.2V 1.5Ah

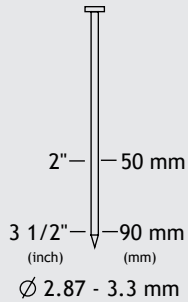

APPLICATION

- Framing
- Sheathing
- Siding
- Trusses
- Bridging
- Wood to masonry
- Engineered lumber
- Fencing
- Exterior decks
- Timber

FEATURES

- Portable and convenient operation
- Powerful, drive 2"-3 1/2" nails for every framing job
- Light weight and well balanced
- Adjustable depth control
- Anti-dry fire mechanism
- Improved air filter effectively prevent dust
- Collapsible reversible hook
- Low battery & high temperature indicator light
- Full sequential actuation
- Patented structure for easy cleaning, repairing and maintenance

100

FASTENING A DIFFERENCE

GFN3490H Gas Framing Nailer



L x W x H	378x374x110 mm
Weight	3.6 kgs
Loading Capacity	68pcs
Diameter	Ø 2.87~3.33 mm
Battery Capacity	4000 nails
Fastener Range	50 - 90 mm
Battery Type	Ni-Mh 7.2V 1.5Ah

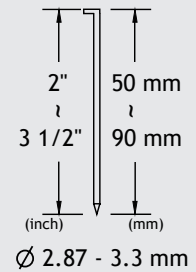

APPLICATION

- Framing
- Sheathing
- Siding
- Trusses
- Bridging
- Wood to masonry
- Engineered lumber
- Fencing
- Exterior decks
- Timber

FEATURES

- Portable and convenient operation
- Powerful, drive 2"-3 1/2" nails for every framing job
- Light weight and well balanced
- Adjustable depth control
- Anti-dry fire mechanism
- Improved air filter effectively prevent dust
- Collapsible reversible hook
- Low battery & high temperature indicator light
- Full sequential actuation
- Patented structure for easy cleaning, repairing and maintenance

GSN2738 Gas Concrete Nailer

L x W x H	393x338x100mm
Weight	3.5 kgs
Available Pin Size	13mm~38mm
Magazine Capacity	40 Pins
Battery Capability	3000 pins
Recharge Time	2.5 hours
Battery Type	Ni-Mh 6V 1.4Ah
Shank diameter	2.7mm
Head diameter	6.3mm
Fastener Diameter	
Fasteners Length	
Shots per charge	
Ni-Mh Battery	
Charge time	
Fastener Capacity	
Loading Capacity	
Diameter	
Battery life	
Fuel rod life	
Leng	

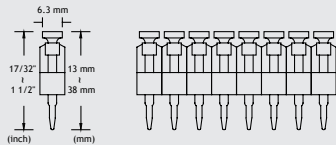

APPLICATION

- Framing
- Sheathing
- Siding
- Trusses
- Bridging
- Wood to masonry
- Engineered lumber
- Fencing
- Exterior decks

FEATURES

- **Debris Shield** / Protects tool and operation from concrete chips
- **High-Voltage Ignition** / For more power and cleaner combustion
- **Ready-Light System** / Indicates if battery has been disabled by power save circuitry
- **High Capacity Magazine** / Holds four strips of fasteners
- **Back Reset** / Provides positive right angle positioning

GFN3490 Gas Framing Nailer



L x W x H	388x378x107mm
Weight	3.5 kgs
Available Pin Size	50mm-90mm
Magazine Capacity	50 Pins
Battery Capability	3000 pins
Recharge Time	2.5 hours
Battery Type	Ni-Mh 6V 1.4Ah
Shank diameter	2.8-3.1 mm
Fastener Diameter	
Fasteners Length	
Shots per charge	
Ni-Mh Battery	
Charge time	
Fastener Capacity	
Loading Capacity	
Diameter	
Battery life	
Fuel rod life	
Leng	

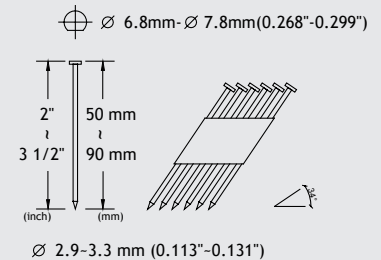

APPLICATION

- Framing
- Sheathing
- Siding
- Trusses
- Bridging
- Wood to masonry
- Engineered lumber
- Fencing
- Exterior decks

FEATURES

- Lock out mechaism Prevent blank firing and minimize tool damagepatent
- Two - step Rear loading
- Utility belt hook for left and right
- Narrow N Easier to reach tight corner
- Tool - free Depth Adjustments
- Easy to Open Filter Cap convenient to clean the air filter and cylinder
- Light battery indicator

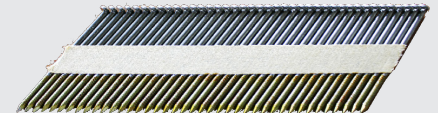



GF1820B Gas Concrete Nailer

L x W x H	320x86x286 mm
Weight	2.34 kg
Available Pin Size	
Shots per charge	4500 ↑
Ni-Mh Battery	
Charge time	2 hours
Loading Capacity	
Nail length	15,19,25,30,32,38,40,45,50



APPLICATION

- Framing
- Sheathing
- Siding
- Trusses
- Bridging
- Wood to masonry
- Engineered lumber
- Fencing
- Exterior decks

FEATURES

G1664 16 Gauge Cordless Gas Finish Nailer



APPLICATION

- Interior finish and trim
- Exterior finish and trim
- Furniture
- Cabinet work
- Staircases

FEATURES

- All-Metal Thumbwheel Adjustable Depth-of-Drive, For precise depth control
- High-Voltage Ignition, For more power and cleaner combustion
- Dry fire lock out, Minimize damage
- Full Comfort Grip, Resilient grip reduces fatigue
- Quick release mechanism, enables jam clearance without tool disassembly
- Belt Hook, wrench storage
- No mar pad, to protect the work piece
- Pear Loading, Quick and easy for right or left handers
- Ni-MH Battery, Long service life

L x W x H	320x86x270 mm
Weight	2.15 kg
Shots per charge	4500↑
Ni-Mh Battery	
Charge time	2 hours
Loading Capacity	42 Nails
Ni-Mh Battery	6V, 1.65Ah
Nail length	25, 32, 38, 45, 50, 57, 64

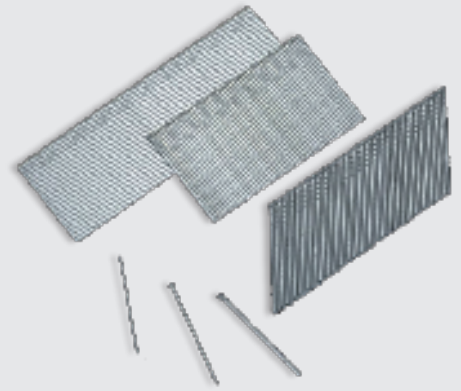

G2640CP Gas Concrete Pin Nailer

L x W x H	459x139x373 mm
Weight	4.0 kg
Shots per charge	4500 ↑
Ni-Mh Battery	2 hours
Charge time	2 hours
Fastener Capacity	42 Nails
Ni-Mh Battery	6V, 1.65Ah
Nail length	15~40

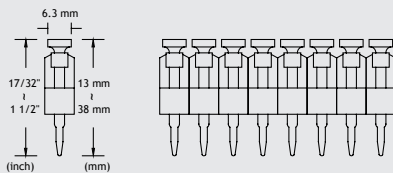

APPLICATION

- Pallet crates
- Drywall on wood strip
- Drywall on metal
- Timber sub - framing

FEATURES

- All-Metal Thumbwheel Adjustable Depth-of-Drive, For precise depth control
- High-Voltage Ignition, For more power and cleaner combustion
- Dry fire lock out, Minimize damage
- Full Comfort Grip, Reilient grip reduces fatigue
- Ready - Light System, Indicates if battery has been disables by power save circuitry
- Debris Shield, Protects tool and operation from concrete chips
- High Capacity Magazine, Holds four strips of fasteners
- Back Reset, Provides positive right angle positioning
- EZ-Clear Door, Minimize damage
- Belt Hook

G2290FN 22 Degree Cordless Gas Framing Nailer



L x W x H	366x108x375 mm
Weight	3.57 kg
Loading	32 Nails
Shots per charge Ni-Mh Battery	4500 ↑
Charge time	2 hours
Rang	50-90 mm
Ni-Mh Battery	6V, 1.65Ah
Nail length	20 degree

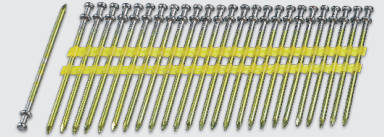

APPLICATION

- Framing
- Sheathing
- Siding
- Wood to masonry
- Engineered lumber
- Fencing
- Exterior decks
- Timber
- Bridging

FEATURES

- All-Metal Thumbwheel Adjustable Depth-of-Drive, For precise depth control
- High-Voltage Ignition, For more power and cleaner combustion
- Dry fire lock out, Minimize damage
- Full Comfort Grip, Reilient grip reduces fatigue
- Ready - Light System, Indicates if battery has been disables by power save circuitry
- Aggressive Toenail Safety, Teeth grip studs with real bite for precise positioning
- In-line Magazine, Better line of sight for right and left handers, improves balance and reduces fatigue
- Ni-MH Battery, Long service life
- Optional Hook, * Rafter Hook * Belt Hook

G3490FN 34 Degree Cordless Gas Framing Nailer

L x W x H	366x108x375 mm
Weight	3.57 kg
Shots per charge	4500 ↑
Ni-Mh Battery	
Charge time	2 hours
Loading Capacity	60
Ni-Mh Battery	6V, 1.65Ah
Nail length	20 degree

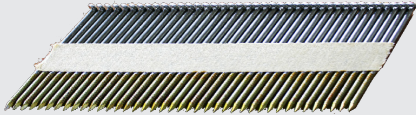

⌀ 6.8mm-⌀ 7.8mm(0.268"-0.299")

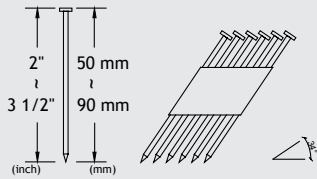

⌀ 2.9-3.3 mm (0.113"-0.131")



APPLICATION

- Framing
- Sheathing
- Siding
- Wood to masonry
- Engineered lumber
- Fencing
- Exterior decks
- Timber
- Bridging

FEATURES

- All-Metal Thumbwheel Adjustable Depth-of-Drive / For precise depth control
- High-Voltage Ignition / For more power and cleaner combustion
- Dry fire lock out / Minimize damage
- Rear Two-step Loading / Quick and easy for right or left handers
- Full Comfort Grip / Reilient grip reduces fatigue
- Aggressive Toenail Safety / Teeth grip studs with real bite for precise positioning
- Optional Hook / * Rafter Hook * Belt Hook
- Ni-MH Battery / Long service life

110

FASTENING A DIFFERENCE

G2640CP Gas Concrete Nailer



L x W x H	320x86x280 mm
Weight	2.16 kg
Shots per charge	4500 ↑
Ni-Mh Battery	
Charge time	2 hours
Fastener Capacity	
Ni-Mh Battery	6V, 1.65Ah
Nail length	

APPLICATION

- Framing
- Sheathing
- Siding
- Trusses
- Bridging
- Wood to masonry
- Engineered lumber
- Fencing
- Exterior decks

FEATURES

- All-Metal Thumbwheel Adjustable Depth-of-Drive / For precise depth control
- High-Voltage Ignition / For more power and cleaner combustion
- Quick release mechanism / enables jam clearance without tool disassembly
- No mar pad / to protect the work piece
- Dry fire lock out / Minimize damage
- Rear Two-step Loading / Quick and easy for right or left handers
- Belt Hook w/wrench storage
- Full Comfort Grip / Resilient grip reduces fatigue

A3464-N5 15 Gauge Cordless Gas Finish Nailer

L x W x H	320x134x305 mm
Weight	2.28 kg
Shots per charge	4500 ↑
Ni-Mh Battery	
Charge time	2 hours
Fastener Capacity	100
Ni-Mh Battery	6V, 1.65Ah
Nail length	32,38,45,50,57,64



APPLICATION

- Framing
- Sheathing
- Siding
- Trusses
- Bridging
- Wood to masonry
- Engineered lumber
- Fencing
- Exterior decks

FEATURES

- All-Metal Thumbwheel Adjustable Depth-of-Drive / For precise depth control
- High-Voltage Ignition / For more power and cleaner combustion
- Quick release mechanism / enables jam clearance without tool disassembly
- No mar pad / to protect the work piece
- Dry fire lock out / Minimize damage
- Comfort Grip / Reillient grip reduces fatigue
- Pear Loading / Quick and easy for right or left handers
- Belt Hook w/wrench storage

T2264G-A1 Gas Concrete Nailer



L x W x H	370x108x365 mm
Weight	3.87 kg
Shots per charge	4500 ↑
Ni-Mh Battery	4500 ↑
Charge time	2 hours
Fastener Capacity	80
Ni-Mh Battery	6V, 1.65Ah
Nail length	18,25,30,32,38,45,50,57,64

APPLICATION

- Framing
- Sheathing
- Siding
- Trusses
- Bridging
- Wood to masonry
- Engineered lumber
- Fencing
- Exterior decks

FEATURES

Gas Fuel Cell Pack



C1

Tool Models Suitable Paslode IM350, Paslode CF 325, Senco Gt90-CH, Max GS683CH, Bea D90S

Height	165 mm
Weight Of Empty Can	46 g
Net Weight Of Gas	40 g
Gross Weight	86 g
Capacity	80 ml
Diameter Of Gas Can	31.6 mm
Fuel Cell Life	1,000~1,100 nails



C2

Tool Models Suitable Powers C3, Puls 700, Hitachi NC50G

Height	152 mm
Weight Of Empty Can	42 g
Net Weight Of Gas	38 g
Gross Weight	80 g
Capacity	70 ml
Diameter Of Gas Can	31.6 mm
Fuel Cell Life	1,000~1,100 nails



C3

Tool Models Suitable SPIT

Height	115 mm
Weight Of Empty Can	35 g
Net Weight Of Gas	27 g
Gross Weight	62 g
Capacity	45 ml
Diameter Of Gas Can	31.6 mm
Fuel Cell Life	1,000~1,100 nails



C4

Tool Models Suitable Hitachi NT65GS, Hitachi NT65GB, Paslode IM250, Paslode IM250A

Height	115 mm
Weight Of Empty Can	35 g
Net Weight Of Gas	27 g
Gross Weight	62 g
Capacity	45 ml
Diameter Of Gas Can	31.6 mm
Fuel Cell Life	1,000~1,100 nails

RAG401

14 oz Continuous Air Grease Gun

Working Pressure	90 PSI
Weight	1 kgs
Out Pressure	3800 PSI
Input Pressure	40~100 PSI
Capacity Cartridge	14 oz
Capacity Bulk	450 cc
Air Inlet	1/4"
Hose Size	3/8" I.D.



TAIWAN
EXCELLENCE 2010



APPLICATION

- For agricultural automotive and industrial applica
- Supplied complete with rigid and flexible delivery tubes
- Lubricate for automotive/ vehicle/ machinery/ farm equipment/ lawn mower and garden equipment
- Industrial applicatios
- ATVS and snow mobiles
- Trailers
- Boats

FEATURES

- Heavy duty fiber composite body fo durability and long life
- 3-way loading-Bulk, filler pump or 14oz grease cartridge
- Bleader Valve for purging unwanted air
- 4-Jaw super grip coupler for better grip and longer service life
- Non-Slip knurled better grip
- Quality satisfaction
- High-standard technique
- Creative products

116

CG1216 Cordless Grease Gun

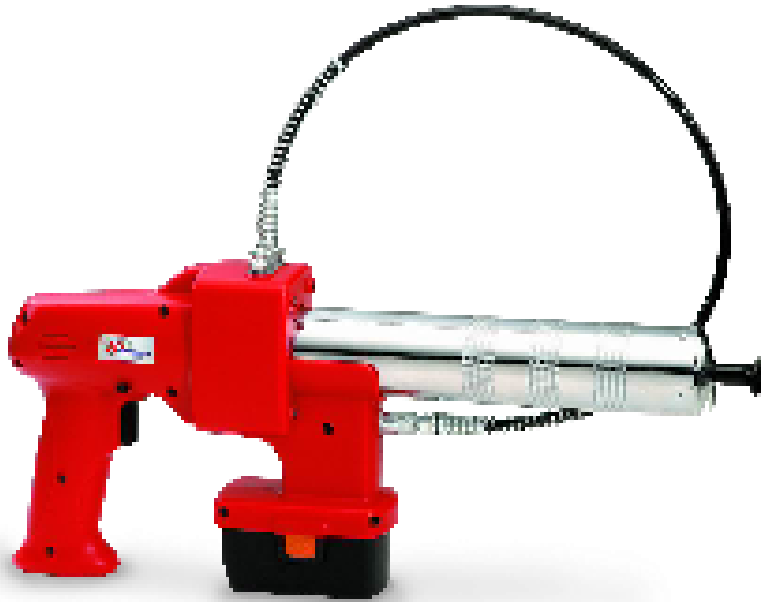

Working Pressure	6000 PSI
Weight	3.2 kgs
3-Way grease loading	bulk, filler pump or 14oz cartridge
Grease Capacity	14oz. (400cc/397g) cartridge or 16oz. (500cc/454g) bulk
Grease Output	6oz./min. (170g/min.) at normal pressure
Time Takes To Dispense One 14 oz. Cartridge	2.5 minutes
One Full Charged Battery Could Dispens	>8 gease cartridges
Including	1grease gun+1battery+1 battery charger
Low Noisy < 80dBa	
Lubricant (Grease)	
Up to NLGI#2	



APPLICATION

- For agricultural automotive and industrial applica
- Supplied complete with rigid and flexible delivery tubes
- Lubricate for automotive/ vehicle/ machinery/ farm equipment/ lawn mower and garden eqnipment
- Industrial applicatios
- ATVS and snow mobiles
- Trailers
- Boats

FEATURES

- Patent reciprocal mechanism design. It makes our grease gun more powerful and has high performance.
- High torque & High pressure & High output:
 - (a)Working pressure 0~10,000psi (our factory preset at 6,000psi). Moreover the gun with release valve, if the working pressure is over 6,000psi, the grease will return to the barrel to protect the motor, enhance tool's service life.
 - (b)Twin Piston (Double current capacity): Average output is 170g/ per min which is 3 times than the others.
 - (c)One full charged battery can dispense 8~11 grease cartridges.
- PWM trigger: Adjustable speed trigger, you can control discharging rate easily.
- Portable, quick continuous discharging rate, it is convenient for emergency or daily maintenance work outdoor. Such as military equipment, tank, armored vehicle, construction equipment, excavator, crane, truck and general industrial machine.

FCN1650

Industrial Flooring Combi Nailer

L x W x H	179x31x213 mm
Weight	115kgs
Operating Pressure	70~120psi
Fasteners Length	1 1/2-2 for staple 1-2 for cleat
Wire Diameter	16 gauge
Fastener Capacity	112 for staple 96 for cleat

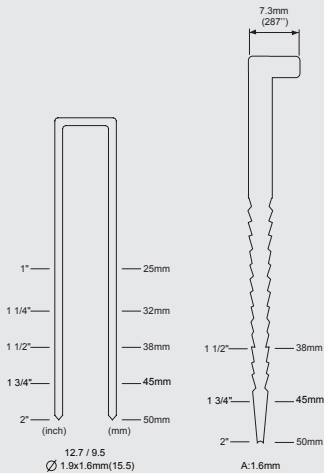

FEATURES

- Front Exhaust
- Ergonomic long reach handle for easier and comfortable operation (also available for short handle)
- Depth adjustable Non-Marring base for 1/2" & 3/4" wood
- High capacity easy to load magazine
- Special treatment of driver to last longer life
- Safety trigger to prevent operation accident-Only for long handle version

APPLICATION

- Installation of hardwood flooring

118

FASTENING A DIFFERENCE

TA1755/TA4055 Corded Auto Feed Screwdriver

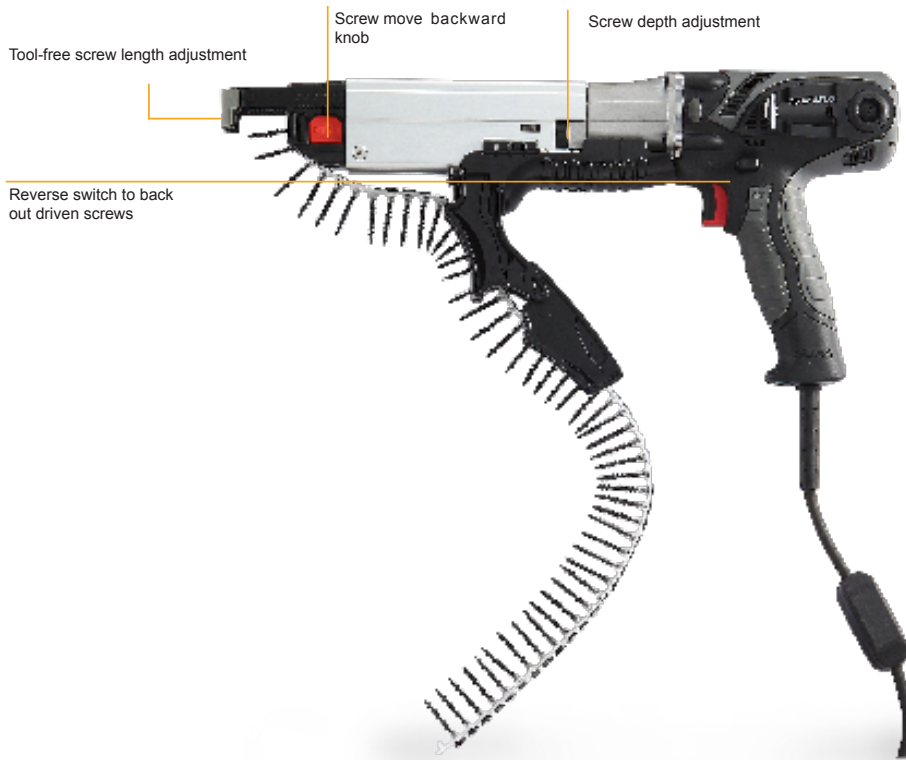

TA1755

L x W x H	410x80x190 mm
Weight	1.8 kgs
Voltage	110/220 V; 50/60HZ
Power In-Put	400 watt / 500 watt
Power Out-Put	3143.3 watt
No-Load Speed	1,700 RPM
No-Load Current	1.5~3.0 A
Fastener Range	25~55 mm(#6~#8)
Max. Torque	80kg-cm(5.76 ft-lb)
Cord Length	1.9 m

TA4055

L x W x H	410x80x190 mm
Weight	1.8 kgs
Voltage	110/220 V; 50/60HZ
Power In-Put	400 watt / 500 watt
Power Out-Put	3451.48 watt
No-Load Speed	4,200 RPM
No-Load Current	1.5~3.5 A
Fastener Range	25~55 mm(#6~#8)
Max. Torque	180kg-cm(13 ft-lb)
Cord Length	1.9 m

FEATURES

- Accurate and reliable feeding system for maximum and fast works
- Screws guard to prevent interfere during operation
- Easy-to-drive making on adjustable nosepiece for different screws length
- Coupler quick change knob convenient and easier exchange the adapter for different brand power tool
- Easy depth adjustable for flush drive or countersink
- Tool-Free screw depth adjustment dial
- Vary adapters available for different brand power tool
- High torque motor
- Forward and reverse switch
- Convenient belt hook
- Trigger lock for continuous work
- Rubber grip for comfort
- Silent clutch

TD1455LIL/TD1855LIL/TD1455LIH/TD1855LIH Cordless Auto Feed Screwdriver

TD 1455 LIL

L x W x H	386x80x250mm
Weight	2.2 kgs
Voltage	14.4 V. Low - for Hard wood / Drywall
No-Load Speed	1,900 RPM
MAX. Torque	33.8 kg-cm (2.43ft-lb)
Fastener Range	25-55 mm
Charging Time	1 Hour Auto Cut-Off
Battery Ampacity	3,000 mAh
Battery Pack	Li-ion Battery
Driver Bit	Square/Phillips drive
Bit Spec.	5.5x154mm
Fastener Capacity	50 pcs

TD 1855 LIL

L x W x H	386x80x250mm
Weight	2.32 kgs
Voltage	18.0 V. Low - for Hard wood / Drywall
No-Load Speed	1,600 RPM
MAX. Torque	48 kg-cm (3.46ft-lb)
Fastener Range	25-55 mm
Charging Time	1 Hour Auto Cut-Off
Battery Ampacity	3,000 mAh
Battery Pack	Li-ion Battery
Driver Bit	Square/Phillips drive
Bit Spec.	5.5x154mm
Fastener Capacity	50 pcs

TD 1455 LIH

L x W x H	386x80x250mm
Weight	2.72 kgs
Voltage	14.4 V. Low - for Soft wood
No-Load Speed	4,500 RPM
MAX. Torque	17.6 kg-cm (1.27ft-lb)
Fastener Range	25-55 mm
Charging Time	1 Hour Auto Cut-Off
Battery Ampacity	3,000 mAh
Battery Pack	Li-ion Battery
Driver Bit	Square/Phillips drive
Bit Spec.	5.5x154mm
Fastener Capacity	50 pcs

TD 1855 LIH

L x W x H	386x80x250mm
Weight	2.3 kgs
Voltage	18.0 V. Low - for Soft wood
No-Load Speed	4,000 RPM
MAX. Torque	23.6 kg-cm (1.7ft-lb)
Fastener Range	25-55 mm
Charging Time	1 Hour Auto Cut-Off
Battery Ampacity	3,000 mAh
Battery Pack	Li-ion Battery
Driver Bit	Square/Phillips drive
Bit Spec.	5.5x154mm
Fastener Capacity	50 pcs



APPLICATION

- Drywall to Wood
- Drywall to light Ga. Steel
- Drywall to Heavy Ga. Steel
- Decking - Wood to Wood
- Flooring - Plywood to Wood
- Wood Flooring
- Underlayment
- Composite Decking
- Cement Board

FEATURES

- Battery power indication
- Accurate and reliable auto feeding mechanism for maximum and fast works
- Depth adjustable for flush drive or countersink
- Easy-to-drive adjustable nosepiece for different screws length
- Coupler quick change knob convenient and easier exchange the adapter for different brand power tool
- Screw Guard to prevent interfere during operation
- Super treatment bits to last longest life
- High torque motor and high efficiency
- Light-Weight
- Convenient belt hook
- Depth of drive adjustment for flush drive or countersink
- High efficiency fan cooled and changeable carbon brush motor
- Forward / Reserve Switch
- Silent clutch
- Reverse button for releasing collated screws
- Tool-Free screw length adjustment

APPLICATIONS



Drywall to wood



Wood to wood



Exterior Wood to the Best Wood



Interior Wood to Wood

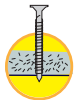

Drywall to Heavy Gauge Steel



Wood to Heavy Gauge Steel



Exterior Wood to the Better Wood



Drywall to Light Gauge Steel

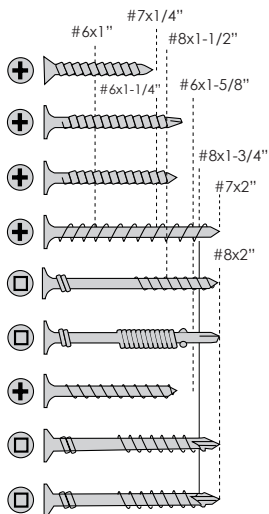

MD1475

Cordless Auto Feed Screwdriver

L x W x H	
Weight	3.4 kgs
No-load Speed	3200RPM
Max. Torque	5.8 N-m / 52 in-lbs
Fastener Range	32 ~ 75 mm (#6, #8, #10)
Charging Time	1hr.
Battery Pack	Ni-ion Battery



APPLICATION

- Drywall to Wood
- Drywall to light Ga,Steel
- Drywall to Heavy Ga,Steel
- Decking - Wood to Wood
- Flooring - Plywood to Wood
- Wood Flooring
- Undertayment
- Composite Decking
- Cement Bcard

FEATURES

- High torque motor
- Auto Feed mechanism in high speed fastening continuously
- Easy-to-drive making on adjustable nosepiece
- Convenient Belt Hook
- Depth of drive adjustment for flush drive or countersink
- High efficiency fan cooled and changeable carbon brush motor
- Electric brake switch and reversible function
- Double injections housing
- Silent clutch
- LED Light indicator
- Ergonomic grip

MDE75 Cordless Auto Feed Screwdriver with Extension Bar



L x W x H	782x20x237 mm
Weight	3.4 kgs
No-load Speed	3200RPM
Max. Torque	5.8 N-m / 52 in-lbs
Fastener Range	32 ~ 75 mm (#6, #8, #10)
Charging Time	1hr.
Battery Pack	Ni-ion Battery

APPLICATION

- Drywall to Wood
- Remolders
- Floor sheathing
- Decking
- Underlayment
- Cement board and fencing
- Drywalling on metal sheets
- Wood construction
- Ceiling application
- Metal construction
- Packing industry

FEATURES

- High torque motor
- Auto Feed mechanism in high speed fastening continuously
- Easy-to-drive making on adjustable nosepiece
- Convenient Belt Hook
- Depth of drive adjustment for flush drive or countersink
- High efficiency fan cooled and changeable carbon brush motor
- Electric brake switch and reversible function
- Double injections housing
- Silent clutch
- LED Light indicator
- Ergonomic grip



MD1455

L x W x H	385x62x175 mm
Weight	3.4kgs
Voltage	14.4V
Unload Speed	2500~3200rpm
Max torque	5.8 N-m / 52 in-lbs



FEATURES

- Cordless Screw Fastening Drive

APPLICATION

- Battery power indication
- Accurate and reliable auto feeding mechanism for maximum and fast works
- Depth adjustable for flush drive or countersink
- Easy-to-drive adjustable nosepiece for different screws length
- Coupler quick change knob convenient and easier exchange the adapter for different brand power tool
- Screw Guard to prevent interfere during operation
- Super treatment bits to last longest life
- High torque motor and high efficiency
- Light-Weight
- Convenient belt hook
- Depth of drive adjustment for flush drive or countersink
- High efficiency fan cooled and changeable carbon brush motor
- Forward / Reserve Switch
- Silent clutch
- Reverse button for releasing collated screws
- Tool-Free screw length adjustment

AS1648 Corded Auto Feed Screwdriver AS1648



AS1648

L x W x H	70x190x340 mm
Weight	2.28 kgs
Screw Length	16-48 mm
Fastener Range	3.0-4.8 mm
Including	2Wrenches, 1 pc Driver, Owner's Manuals

C14 Manual Feed Hog Ring Plier

L x W x H	175x120x15mm
Weight	0.2kgs
Gauge	16 GA
Shank Dia	1.9mm(0.075")
Fastener Range	14mm(9/16")
Closure Size	Rhombus
Loading Capacity	1 pcs

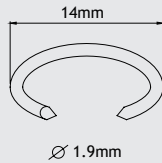

FEATURES

- A spring keeps the hog ring plier jaws open for easy loading
- Hog rings are loaded one at a time
- Pliers accept strong 14 gauge hog rings in galvanized or stainless steel

APPLICATION

- Seating
- Wire Mesh
- Erosion Control
- Bedding
- General

M1618/M20 OMEGA PLIERS



APPLICATION

- Wire netting
- Chain link fencing
- Bagging
- Poultry caging
- Rope tying
- Insulation

FEATURES

- Light and handy tool with easy fit magazine
- 50 hog ring magazine load capacity
- Professional – robust construction
- Anti-rust coating
- The perfect tool to fix young plants, secure growing branches and attach a net
- Automatically feeds the rings into the jaws
- The magazine pivots to allow tool to reach into difficult areas

M1618T

L x W x H	190x120x165 mm
Weight	0.32 kgs
Wire Size	1.3 mm
Crown	16 mm
Package	1 PCS/ BLISTER CARD
Load Capacity	50 pcs

M20

L x W x H	190x130x170 mm
Weight	0.36 kgs
Wire Size	2.0 mm
Crown	20 mm
Package	1 PCS/ BLISTER CARD
Load Capacity	50 pcs

Omega Ring Size



M1618T

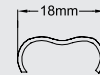

M1618T

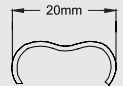

M20

Closure Size

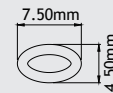

M1618T

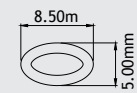

M1618T

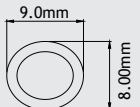

M20



C8 Manual C Ring Plier

L x W x H	1850x100x22mm
Weight	0.34kgs
Gauge	16 GA
Shank Dia	1.20x1.75mm (0.50x0.069")
Crown	19.5 mm
Closure Size	7~9 mm
Loading Capacity	50 pcs

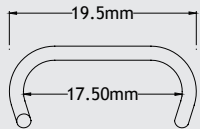

3/8" 9.2~9.6mm

Closure Size

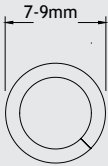

FEATURES

- Automatic feed
- One-Hand operation
- Black coated finish
- Anti-Slip red handles
- Chrome-Plated magazine
- Spring magazin feed
- magazine capacity: 50PCS

APPLICATION

- Closing mesh poultry bag
- Fencing
- Nursery
- Cage frame
- Netting
- Gabion basket installations
- Small bag closure

D15 15GA.Manual D Ring Plier

L x W x H	210x100x23 mm
Weight	0.5kgs
Gauge	15 GA
Shank Dia	1.85x2.05mm (0.073"x0.081")
Crown	22 mm
Closure Size	5~7mm(3/16"-9/32")
Loading Capacity	50 pcs

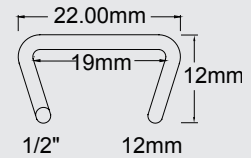

Closure Size



FEATURES

- All steel construction
- Black coated finish
- Anti-Slip handles
- Chrome-Plated magazine
- Spring magazine feed
- One hand operation

APPLICATION

- Netting
- Fencing
- Nursery
- Garland
- Closing wire mesh products
- Gabion basket installations
- Large bag closures

PC093

Portable Compressed CO2 Regulator

L x W x H	127x105x133 mm
Weight	0.7 kgs
Working Pressure	6000 PSI
Weight	3.2 kgs
3-Way grease loading	bulk, filler pump or 14oz cartridge
Grease Capacity	14oz. (400cc/397g) cartridge or 16oz. (500cc/454g) bulk
Grease Output	6oz./min. (170g/min.) at normal pressure



APPLICATION	CO2 CYLINDER CAPACITY (OZ.)
	20 (OZ.)
2 IN 1 AIR NAILER & STAPLER Standard 18 GA brads 2'' (50mm) Standard 18 GA staple 19/16'' (40mm)	900
AIR STAPLER Standard 21 GA staple 5/8'' (16mm)	1500
16GA BRAD NAILER Standard 16 GA brads 2'' (50mm)	1200
WIRE FINISH NAILER Standard 18 GA brads 1/4'' (32mm)	1300

- Uses refillable liquid CO2 cylinders. It provides all the power of a traditional air compressor but fits into the palm of your hand.
- The pneumatic stapler suitable for use with JaPac operates in a range between 20-100psi pressure.
- The regulator, hose and liquid CO2 cylinder, hooks onto your belt and fits any standard pneumatic tool. The enormous energy contained in liquid CO2 gives you full power to operate your pneumatic - air powered - hand tools without the need of a traditional air compressor.

APPLICATION

- Upholstery, Automotive Mechanic's Onsite And Offsite Repairs / Works.

FEATURES

- Hooks to your belt and goes where you go
- Full power for quick fire, single shot tools such as brad nailers, pin and roofing nailers, finishing, framing, staplers, caulking and grease guns.
- Universal connector attaches to any standard pneumatic tools
- 20 oz CO2 cylinder shoots 1500 1" (25mm) brad nails or 500 1" (25mm) narrow crown staples.
- No more lugging heavy air compressors or tangled air hoses
- No more lengthy set-up times - sets up in under 2 minutes
- Complete Portable CO2 power system weighs 2.2 kgs.
- Environmentally friendly - reusable cylinders, quiet operation
- Saving time and efforts without sacrificing quality

130

FASTENING A DIFFERENCE

Application of PC093



Wood Floor Nailing



Motorcycle Tires Air Inflation



Wood Materials Polishing



Auto Tires Air Inflation

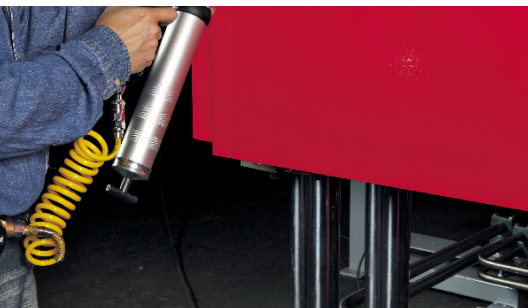

For Greasing Machinery



Machinery Air Blowing

Application of PC093



Bike Tires Air Inflation



Sports Equipments Greasing



For Coil Roofing Nailer

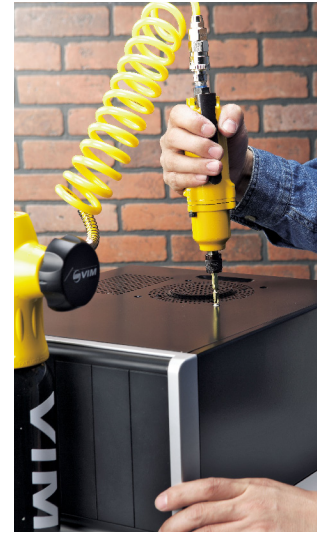

Air Screwdriver



Upholstery Stapling



Window, Door, Bathroom Caulking



Wood working Air Blowing



Machinery Parts Grinding

OILESS AC SERIES 1/4 HP MINI COMPRESSOR



L x W x H	287x130x252 mm
Net Weight	4.5 kgs
Horsepower	1/4 HP
Tank Capacity	0.8 L
Power Supply	100-120 V; 220-240 V / 50Hz
Rated Amps	6.1 Amp
Air Delivery	35 L/min
RPM	3500 RPM
Pressure Switch ON	6 bar (85 psi)
Pressure Switch OFF	8 bar (115 psi)
Pump Type	Oil-Less
Noise Level (dBa)	67 dBa
Certification	



FEATURES

- Multipurpose, compact and light weight
- Maintenance free
- Built-in air regulator and pressure switch
- Automatic reset thermal overload protector
- Approval: CE, UL
- Perfect for diy or semi-professional users, air nailers, air brushes, low pressure spray gun, 4x4 van tire inflator



Accessory:



LV0204 AIR COMPRESSOR

L x W x H	250x250x350mm
Net Weight	8.5kgs
Horsepower	1/6 HP
Tank Capacity	1 Gallon (4L)
Power Supply	European Type 230 V / 50Hz; USA Type 115 V / 60 Hz
Rated Amps	European Type 1.6 Amp; USA Type 0.7 Amp
Air Delivery	25.1 L/min
SCFM@40PSI	0.7
SCFM@90PSI	0.54
RPM	European Type 2840 RPM; USA Type 3450 RPM
Pressure Switch ON	6 bar (85 psi)
Pressure Switch OFF	8 bar (115 psi)
Pump Type	Oil-Less
Noise Level (dBa)	69 dBa
Certification	CE



FEATURES

- Oil-Free operation reduces maintenance
- Highly portable and exceptionally easy to use
- Complete with built-in automatic thermal overload protection
- Pancake-Style tank ensures stability
- Rubber feet that won't scratch or mar wood surfaces
- Light-weight, Gose anywhere you do, at only 8.5kgs
- Quiet operation and long life
- Easy-to-read pressure gauge
- Sturdy handle for easier storage and handling
- Induction motor / pump that provides efficient operation and optimum performance

LV2012 Oil-Less 2.0 HP Air compressor



FEATURES

- Need not to use lubricant for clean and oil-less air, so it is trouble-free to require for oil and dirt
- Low power consumption, handy and convenient, fully-auto control, motor overloading protective device
- Suitable for family, outdoors, and indoors decoration, nailing, and painting

For European & USA types

L x W x H	530x530x720 mm
Net Weight	33 kgs
Horsepower	2 HP
Tank Capacity	2.6 Gallon (12L)
Power Supply	European Type 230 V / 50Hz; USA Type 115 V / 60Hz
Rated Amps	European Type 5 Amp USA Type 12 Amp
Air Delivery	236 L/min
SCFM@40PSI	4
SCFM@90PSI	3.2
RPM	European Type 2840 RPM; USA Type 3450 RPM
Pressure Switch ON	6 bar (85 psi)
Pressure Switch OFF	8 bar (115 psi)
Pump Type	Oil-Less
Noise Level (db)	82 dBa
Certification	UL CE CSA TUV

LV2520 PORTABLE HEAVY DUTY AIR COMPRESSOR

For European & USA types

L x W x H	700x520x560 mm
Net Weight	41.5 kgs
Horsepower	2.5 HP
Tank Capacity	5.3 Gallon (20L)
Power Supply	European Type 230 V / 50Hz; USA Type 115 V / 60 Hz
Rated Amps	European Type 6.1 Amp; USA Type 14 Amp
Air Delivery	217 L/min
SCFM@40PSI	5.9
SCFM@90PSI	4.5
RPM	European Type 2840 RPM; USA Type 3450 RPM
Pressure Switch ON	6 bar (85 psi)
Pressure Switch OFF	8 bar (115 psi)
Pump Type	Oil-Lube
Noise Level (dBa)	86 dBa
Certification	UL CE CSA TUV



FEATURES

- Built-in Storage Compartment - Conveniently stores air fittings & accessories.
- Oil Lubricated - Cooler running pump, minimum wear.
- Air Hose Wrap - Stores 50' of 3/8" Air Hose with handle folded or upright.
- Tool Hangers - Stores tools when not in use.
- Large automotive style industrial air filter for increased air intake and greater efficiency.
- Durable cast iron cylinder reduces wear and increases pump life; removable for easy maintenance.
- Roll cage construction for extra protection to pump and motor assembly.
- Oil sight glass for fast, easy and efficient maintenance
- Finned discharge tubing for increased heat dissipation and reduced moisture in the air.
- Lever handle ball valve - tank drain valve improves upon standard petcock design. for easier maintenance.
- Convenient oil drain at the front of the pump for easy access.
- Built-in thermal overload for additional motor protection.
- Pneumatic wheels and lifting handles make this unit more portable than any other.
- Easy to read gauges and quick access to regulator and couplers.
- Dual quick couplers to easily support 2 nailers.
- Oil sight glass for fast, easy and efficient maintenance.
- Pneumatic wheels and lifting handles make this unit more portable than any other.
- Air Hose Wrap - Stores 50' of 3/8" Air Hose with handle folded or upright.



Air hose wrap



Pneumatic wheels and lifting handles make it more portable

LV2016A COMPACTEST AIR COMPRESSOR

For USA type only

L x W x H	500x400x440 mm
Net Weight	29 kgs
Horsepower	2 HP
Tank Capacity	4.2 Gallon (16L)
Power Supply	115V/60Hz
Rated Amps	12.5 Amp
Air Delivery	128 L/min
SCFM@40PSI	3.7
SCFM@90PSI	3.2
RPM	3450 RPM
Pressure Switch ON	6 bar (85 psi)
Pressure Switch OFF	8 bar (115 psi)
Pump Type	Oil-Lube
Noise Level (db)	88 dBa
Certification	CSA UL CE



FEATURES

- No need to use lubricant for clean and oil-less air, trouble-free to require for oil and dirt.
- Low power consumption, handy and convenient, fully-auto control, motor overloading protective device.
- Suitable for family, outdoors, and indoors decoration, nailing, and painting.

LV0710 PORTABLE AIR COMPRESSOR



For European type only

L x W x H	480x280x550 mm
Net Weight	21 kgs
Horsepower	3/4 HP
Tank Capacity	2.6 Gallon (10L)
Power Supply	230 V / 50Hz
Rated Amps	3.9 Amp
Air Delivery	75 L/min
SCFM@40PSI	
SCFM@90PSI	
RPM	1430 RPM
Pressure Switch ON	6 bar (85 psi)
Pressure Switch OFF	8 bar (115 psi)
Pump Type	Oil-Lube
Noise Level (dBa)	
Certification	UL CE CSA TUV

FEATURES

- High output - cast iron pump with big bore cylinder and piston, combined with greater bore and stroke, delivers maximum performance.
- Low 73 dBa allows for quieter operation.
- Low Amp draw - reduces incidences of tripped breakers and voltage drop that can cause premature motor failure.
- Oil Lubricated - cooler running pump, minimizes wear.
- Large automotive style industrial air filter for increased air intake and greater efficiency.
- Durable cast iron cylinder reduces wear and increases pump life; removable for easy maintenance.
- Oil sight glass for fast, easy and efficient maintenance.
- Lever handle ball valve - tank drain valve improves upon standard petcock design for easier maintenance.
- Built-in thermal overload for additional motor protection.
- Well positioned lifting handles.

LV2016

JOB-SITE TWINSTACK AIR COMPRESSOR

For European & USA types

L x W x H	520x410x470 mm
Net Weight	30 kgs
Horsepower	2.0 HP
Tank Capacity	4.2 Gallon (16L)
Power Supply	European Type 230V / 50Hz; USA Type 115V / 60Hz
Rated Amps	European Type 7.0 Amp; USA Type 13.0 Amp
Air Delivery	128 L/min
SCFM@40PSI	4.1
SCFM@90PSI	3.4
RPM	European Type 1430 RPM; USA Type 1720 RPM
Pressure Switch ON	6 bar (85 psi)
Pressure Switch OFF	8 bar (115 psi)
Pump Type	Oil-Lube
Noise Level (db)	75 dBA
Certification	UL CE CSA TUV



FEATURES

- Low 82 dBA allows for quieter operation.
- Low Amp Draw - Reduces incidences of tripped breakers and voltage drop that can cause premature motor failure.
- Oil Lubricated - Cooler running pump, minimizes wear.
- Roll-Cage Construction - Complete protection to withstand extreme jobsite environments.
- Large automotive style industrial air filter for increased air intake and greater efficiency.
- Durable cast iron cylinder reduces wear and increases pump life; removable for easy maintenance.
- Oil sight glass for fast, easy and efficient maintenance.
- Lever handle ball valve - tank drain valve improves upon standard petcock design for easier maintenance.
- Built-in thermal overload for additional motor protection.
- Well positioned lifting handles.
- Easy to read gauges and quick access to regulator and couplers.
- Dual quick couplers to easily support 2 nailers.
- Oil sight glass for fast, easy and efficient maintenance.

140

FASTENING A DIFFERENCE

LV1508 OIL-LESS 1.5 HP HEAVY DUTY AIR COMPRESSOR



For USA type only

L x W x H	480x410x410 mm
Net Weight	23 kgs
Horsepower	1.5 HP
Tank Capacity	2.1 Gallon (8L)
Power Supply	115V/60Hz
Rated Amps	12.5 Amp
Air Delivery	153 L/min
SCFM@40PSI	3.8
SCFM@90PSI	3
RPM	1720 RPM
Pressure Switch ON	6 bar (85 psi)
Pressure Switch OFF	8 bar (115 psi)
Pump Type	Oil-Less
Noise Level (db)	75 dBa
Certification	UL CE CSA TUV

FEATURES

- Durable oil free pump provides extended maintenance-free operation.
- Low 88 dBa allows for quieter operation.
- Lightweight (23 kgs) aluminium and compact design is easy to carry and store.
- Dual quick couplers to easily support 2 nailers.
- Roll-bar handle - for portability and additional protection.
- Increased ease of operation and protection of controls and gauge.
- Easy to read gauges and quick access to regulator and couplers.
- Low Amp draw - reduces incidences of tripped breakers and voltage drop that can cause premature motor failure.
- Lever handle ball valve - tank drain valve improves upon standard petcock design for easier maintenance.
- Built-in thermal overload for additional motor protection.

LV0164 COMPACTEST MINI. AIR COMPRESSOR

For European & USA types

L x W x H	290x290x400 mm
Net Weight	8.5 kgs
Horsepower	1/6 HP
Tank Capacity	1 Gallon (4L)
Power Supply	European Type 230 V / 50Hz; USA Type 115V / 60Hz
Rated Amps	European Type 0.7 Amp; USA Type 1.8 Amp
Air Delivery	25.1 L/min
SCFM@40PSI	0.7
SCFM@90PSI	0.54
RPM	European Type 2840 RPM; USA Type 3450 RPM
Pressure Switch ON	6 bar (85 psi)
Pressure Switch OFF	8 bar (115 psi)
Pump Type	Oil-Less
Noise Level (db)	69 dBa
Certification	UL CE CSA TUV



FEATURES

- Low noise and vibration design with compact and simplify outlooks, provide users with easy operation surrounding
- Stable and high efficient air outputs, keep continuing working possible
- High durable inductio motor with safety protect device prolongs working life of machine
- Easy-to-carry design with 3 typical options can easily use this unit everywhere without limits
- Most suitable for finger / toe-nail paintion, model painting or artork painting for fashion or art fields

LV0164CP COMPACTEST MINI. AIR COMPRESSOR



FEATURES

- Durable oil free pump provides extended maintenance-free operation
- Low dBA
- Quiet operation ideal for punch-out, trim, and finish applications
- Aluminium cylinder provides lightest weight for easy carry and store
- Ideal for use with brad nailer, stapler, or finish nailer
- Built-in thermal overload for additional motor protection
- Lever handle ball valve - tank drain valve improves upon standard petcock design for easier maintenance
- Easy to read gauge and dual quick connects

For USA type only

L x W x H	375x300x320 mm
Net Weight	9.4 kgs
Horsepower	1/6 HP
Tank Capacity	1.1 Gallon (4L)
Power Supply	115 / 60Hz
Rated Amps	1.8 Amp
Air Delivery	25.2 L/min
SCFM@40PSI	0.7
SCFM@90PSI	0.54
RPM	3450 RPM
Pressure Switch ON	6 bar (85 psi)
Pressure Switch OFF	8 bar (115 psi)
Pump Type	Oil-Less
Noise Level (db)	69 dBA
Certification	UL CE CSA TUV

LV30100 AIR COMPRESSOR

For European type only

L x W x H	1000x500x750 mm
Net Weight	71 kgs
Horsepower	3 HP
Tank Capacity	26.3 Gallon (100L)
Power Supply	220 V / 50Hz
Rated Amps	11 Amp
Air Delivery	433 L/min
RPM	2840 RPM
Pressure Switch ON	8 bar (115 psi)
Pressure Switch OFF	10 bar (145 psi)
Pump Type	Oil-Lube
Noise Level (db)	88 dBa
Certification	UL CE CSA TUV
Bore and stroke	Φ 47x44x2Px2 cylinders



FEATURES

- Motor direct driving, high efficiency, synch radiation fan, no heat production, double-valve design, quiet and noiseless, fully auto control system, easy to operate, safe and reliable
- Suitably used for decoration, nailing and painting, etc. operation for family, indoors and outdoors handy, convenient, and moveable

3025 AIR COMPRESSOR



L x W x H	640x340x630 mm
Net Weight	41 kgs
Horsepower	3 HP
Tank Capacity	25L
Power Supply	220 V / 50Hz
Rated Amps	11 Amp
Air Delivery	218 L/min
RPM	1450 RPM
Pressure Switch ON	6 bar
Pressure Switch OFF	8 bar
Pump Type	Oil-Lube
Noise Level (db)	80 dBa
Certification	UL CE CSA TUV
Bore and stroke	Φ47x44x2Px2 cylinders

FEATURES

- Motor direct driving, high efficiency, synch radiation fan, no heat production, double-valve design, quiet and noiseless, fully auto control system, easy to operate, safe and reliable
- Suitably used for decoration, nailing and painting, etc. operation for family, indoors and outdoors handy, convenient, and moveable

LV0506 Compact Air Compressor

For European & USA types

L x W x H	470x300x450 mm
Net Weight	15 kgs
Horsepower	1/2 HP
Tank Capacity	1.6 Gallon (6L)
Power Supply	European Type 230 V / 50Hz; USA Type 115 V / 60Hz
Rated Amps	European Type 6.1 Amp USA Type 12 Amp
Air Delivery	74 L/min
SCFM@40PSI	3.5
SCFM@90PSI	3
RPM	European Type 1430RPM; USA Type 1720 RPM
Pressure Switch ON	6 bar (85 psi)
Pressure Switch OFF	8 bar (115 psi)
Pump Type	Oil-Lube
Noise Level (db)	73 dBa
Certification	UL CE CSA TUV



FEATURES

- Delivers long lasting reliable performance
- Well positioned lifting handles
- Quiet operation ideal for punch-out, trim, and finish applications
- Lightweight and easy to carry and store
- Ideal for use with brad nailer, stapler, or finish nailer
- Oil Lubricated - Cooler running pump, minimum wear
- Built-in thermal overload for additional motor protection
- Lever handle ball valve - tank drain valve improves upon standard petcock design for easier maintenance
- Durable cast iron cylinder reduces wear and increases pump life; removable for easy maintenance
- Oil sight glass for fast, easy and efficient maintenance

LV1010 OIL-LESS PORTABLE AIR COMPRESSOR



FEATURES

- Low AMP.
- Durable oil free pump provides extended maintenance-free operation.
- Low 77 dBA allows for quieter operation.
- Lightweight (19 kgs) aluminium cylinder and compact design is easy to carry and store.
- Ideal for use with brad nailer, stapler, or finish nailer.
- Roll-bar handle - for portability and additional protection.
- Plastic guard protects damaged at jobsite.
- Built-in thermal overload for additional motor protection.
- Lever handle ball valve - tank drain valve improves upon standard petcock design for easier maintenance.
- Low Amp draw - reduces incidences of tripped breakers and voltage drop that can cause premature motor failure.

For European & USA types

L x W x H	520x290x520 mm
Net Weight	19 kgs
Horsepower	1.0 HP
Tank Capacity	2.6 Gallon (10L)
Power Supply	European Type 230V/50Hz; USA Type 115V/60Hz
Rated Amps	European Type 3.4 Amp; USA Type 9 Amp
Air Delivery	99 L/min
SCFM@40PSI	2.7
SCFM@90PSI	1.8
RPM	European Type 1430 RPM; USA Type 1720 RPM
Pressure Switch ON	6 bar (85 psi)
Pressure Switch OFF	8 bar (115 psi)
Pump Type	Oil-Less
Noise Level (db)	75 dBA
Certification	UL CE CSA TUV

TS55G 2.0 HP Air Compressor

L x W x H	630x560x550 mm
Net Weight	35 kgs
Horsepower	2 HP
Tank Capacity	16 Gallon (60L)
Air Delivery	318 L/min
RPM	3000 RPM
Pump Type	Oil-Less
Noise Level (db)	82 dBa
Certification	UL CE CSA TUV



FEATURES

- Motor direct driving, high efficiency, synch radiation fan, no heat production, double-valve design, quiet and noiseless, fully auto control system, easy to operate, safe and reliable
- Suitably used for decoration, nailing and painting, etc. operation for family, indoors and outdoors Handy, convenient, and moveable

LV2516 COMPACT AIR COMPRESSOR



For European & USA types

L x W x H	660x550x550 mm
Net Weight	39 kgs
Horsepower	2.5 HP
Tank Capacity	5.2 Gallon (20L)
Power Supply	European Type 230 V / 50Hz; USA Type 115 V / 60HZ
Rated Amps	European Type 8.1 Amp; USA Type 14.5 Amp
Air Delivery	300 L/min
SCFM@40PSI	6.1
SCFM@90PSI	4.9
RPM	European Type 2840 RPM; USA Type 3450 RPM
Pressure Switch ON	6 bar (85 psi)
Pressure Switch OFF	8 bar (115 psi)
Pump Type	Oil-Less
Noise Level (db)	88 dBa
Certification	UL CE CSA TUV

FEATURES

- No need to use lubricant for clean and oil-less air, trouble-free to require for oil and dirt
- Low power consumption, handy and convenient, fully-auto control, motor overloading protective device

TT318E-DV Oil-Lube 3.0 HP Air Compressor

For USA type only

L x W x H	1145x540x690 mm
Net Weight	72.6 kgs
Horsepower	3 HP
Tank Capacity	32 Gallon (145L)
Power Supply	115 V / 60Hz
Rated Amps	14.2 Amp
Air Delivery	231 L/min
SCFM@40PSI	5.8
SCFM@90PSI	4.8
RPM	1230 RPM
Pressure Switch ON	6.5 bar (95 psi)
Pressure Switch OFF	8.5 bar (125 psi)
Pump Type	Oil-Lube
Noise Level (db)	79 dBA
Certification	UL CE CSA TUV



FEATURES

- Durable iron casting cylinder reduce wear
- Abrasion resistant
- High efficiency, easy to operate, safe and reliable
- Oil lubrication system allows pump to be operated on an uneven surface
- Forced Cooler running fan, low heat production
- Ideal for heavy industry, automobile painting & repair

150

FASTENING A DIFFERENCE

LV3060 AANDY 3.0 HPAIR COMPRESSOR



FEATURES

- Motor direct driving, high efficiency, synch radiation fan, no heat production, double-valve design, quiet and noiseless, fully auto control system, easy to operate, safe and reliable
- Suitably used for decoration, nailing and painting, etc. operation for family, indoors and outdoors handy, convenient, and moveable

For European type only

L x W x H	550x490x1080 mm
Net Weight	56 kgs
Horsepower	3 HP
Tank Capacity	15.7 Gallon (60L)
Power Supply	230 V / 50Hz
Rated Amps	11 Amp
Air Delivery	433 L/min
RPM	2840 RPM
Pressure Switch ON	8 bar (115 psi)
Pressure Switch OFF	10 bar (145 psi)
Pump Type	Oil-Lube
Noise Level (db)	88 dBa
Certification	UL CE CSA TUV

TT55G 2.0 HP Air Compressor

L x W x H	1300X540X730 mm
Net Weight	82.5 kgs
Horsepower	2 HP
Tank Capacity	36 Gallon (163L)
Air Delivery	351 L/min
SCFM@40 PSI	9.5
SCFM@90 PSI	8
RPM	1160 RPM
Pump Type	Oil-Lube
Noise Level (db)	88 dBa
Certification	UL CE CSA TUV



FEATURES

- Durable iron casting cylinder reduce wear
- Abrasion Resistant
- Hight efficiency
- Large oil tank can keep long operation
- Forced Cooler running fan
- Low heat production
- Motor direct driving easy to operate, safe and reliable
- Ideal for automobile painting & repair, no power source palce
- Good lubrication

VIM warrants its professional tools for a period of one year from the date of original purchase. We will repair or replace stored option, any part or parts of the product and accessories covered under this warranty which, after examination, proves to be defective in workmanship or material during the warranty period. For repair or replacement, return the complete tool or accessory, transportation prepaid, to vim. This warranty does not apply to o-rings and driver blades or to repair or replacement required due to misuse, abuse, normal wear and tear or repairs attempted or made by other than vim.